



US008766719B2

(12) **United States Patent**  
**Lai et al.**

(10) **Patent No.:** **US 8,766,719 B2**  
(45) **Date of Patent:** **Jul. 1, 2014**

(54) **DIGITALLY-CONTROLLED POWER AMPLIFIER WITH BANDPASS FILTERING/TRANSIENT WAVEFORM CONTROL AND RELATED DIGITALLY-CONTROLLED POWER AMPLIFIER CELL**

8,004,368 B2 *	8/2011	Presti et al. ....	330/10
8,319,530 B2	11/2012	Zhao	
8,411,793 B2 *	4/2013	Staszewski et al. ....	375/297
2002/0030529 A1	3/2002	Lee	
2003/0042984 A1	3/2003	Moloudi	
2011/0200076 A1	8/2011	Mu	
2011/0276113 A1	11/2011	Cybulski	

(75) Inventors: **Jie-Wei Lai**, Taipei (TW);  
**Meng-Hsiung Hung**, Hsinchu (TW);  
**Robert Bogdan Staszewski**, Delft (NL)

**OTHER PUBLICATIONS**

(73) Assignee: **Mediatek Inc.**, Science-Based Industrial Park, Hsin-Chu (TW)

Lai, A World-Band Triple-Mode 802.11a/b/g SOC in 130-nm CMOS, pp. 2911-2921, vol. 44, No. 11, IEEE Journal of Solid-State Circuits, Nov. 2009.

(\*) Notice: Subject to any disclaimer, the term of this patent is extended or adjusted under 35 U.S.C. 154(b) by 69 days.

Mehta, A 0.8mm2 All-Digital SAW-Less Polar Transmitter in 65nm EDGE SoC, pp. 58-59 and a page showing Figure 3.2.7, ISSCC 2010/ Session 3/ Cellular Techniques/ 3.2.

(21) Appl. No.: **13/484,268**

Jerng, A Wideband Delta-Sigma Digital-RF Modulator for High Data Rate Transmitters, pp. 1710-1722, vol. 42, No. 8, IEEE Journal of Solid-State Circuits, Aug. 2007.

(22) Filed: **May 30, 2012**

Chowdhury, A 2.4GHz Mixed-Signal Polar Power Amplifier with Low-Power Integrated Filtering in 65nm CMOS, pp. 1-4, Custom Integrated Circuits Conference (CICC), 2010 IEEE.

(65) **Prior Publication Data**

US 2013/0094611 A1 Apr. 18, 2013

Boos, A Fully Digital Multimode Polar Transmitter Employing 17b RF DAC in 3G Mode, pp. 376-377 and a page showing Figure 21.7.7, ISSCC 2011/ Session 21/ Cellular/ 21.7.

\* cited by examiner

**Related U.S. Application Data**

(60) Provisional application No. 61/548,095, filed on Oct. 17, 2011.

*Primary Examiner* — Khanh V Nguyen

(74) *Attorney, Agent, or Firm* — Winston Hsu; Scott Margo

(51) **Int. Cl.**  
**H03F 1/00** (2006.01)

(57) **ABSTRACT**

(52) **U.S. Cl.**  
USPC ..... **330/151**; 330/129

A digitally-controlled power amplifier (DPA) with bandpass filtering includes a radio-frequency (RF) clock input, an amplitude control word (ACW) input, and a plurality of DPA cells. The RF clock input is arranged for receiving an RF clock. The ACW input is arranged for receiving a digital ACW signal. The DPA cells are coupled to the RF clock and the digital ACW signal, wherein at least one of the DPA cells is gradually turned on and off in response to at least one bit of the digital ACW signal.

(58) **Field of Classification Search**  
USPC ..... 330/127, 129, 151, 297; 375/295-297  
See application file for complete search history.

(56) **References Cited**

**U.S. PATENT DOCUMENTS**

7,149,271 B2	12/2006	Yamada
7,759,992 B2	7/2010	Ibuka
7,929,637 B2 *	4/2011	Staszewski et al. .... 375/295

**20 Claims, 22 Drawing Sheets**

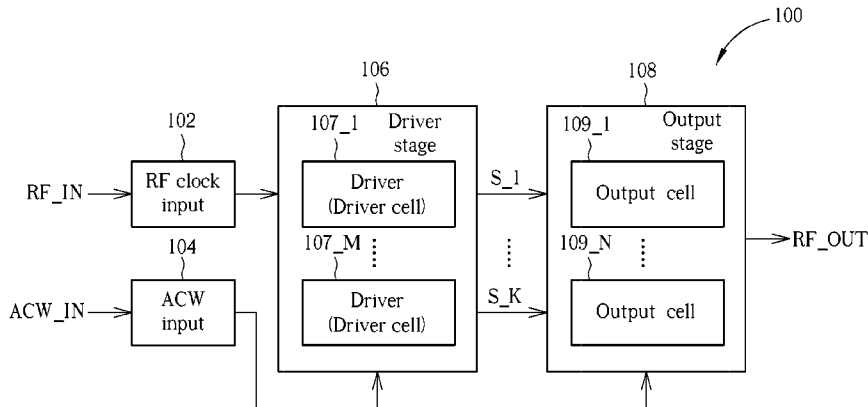

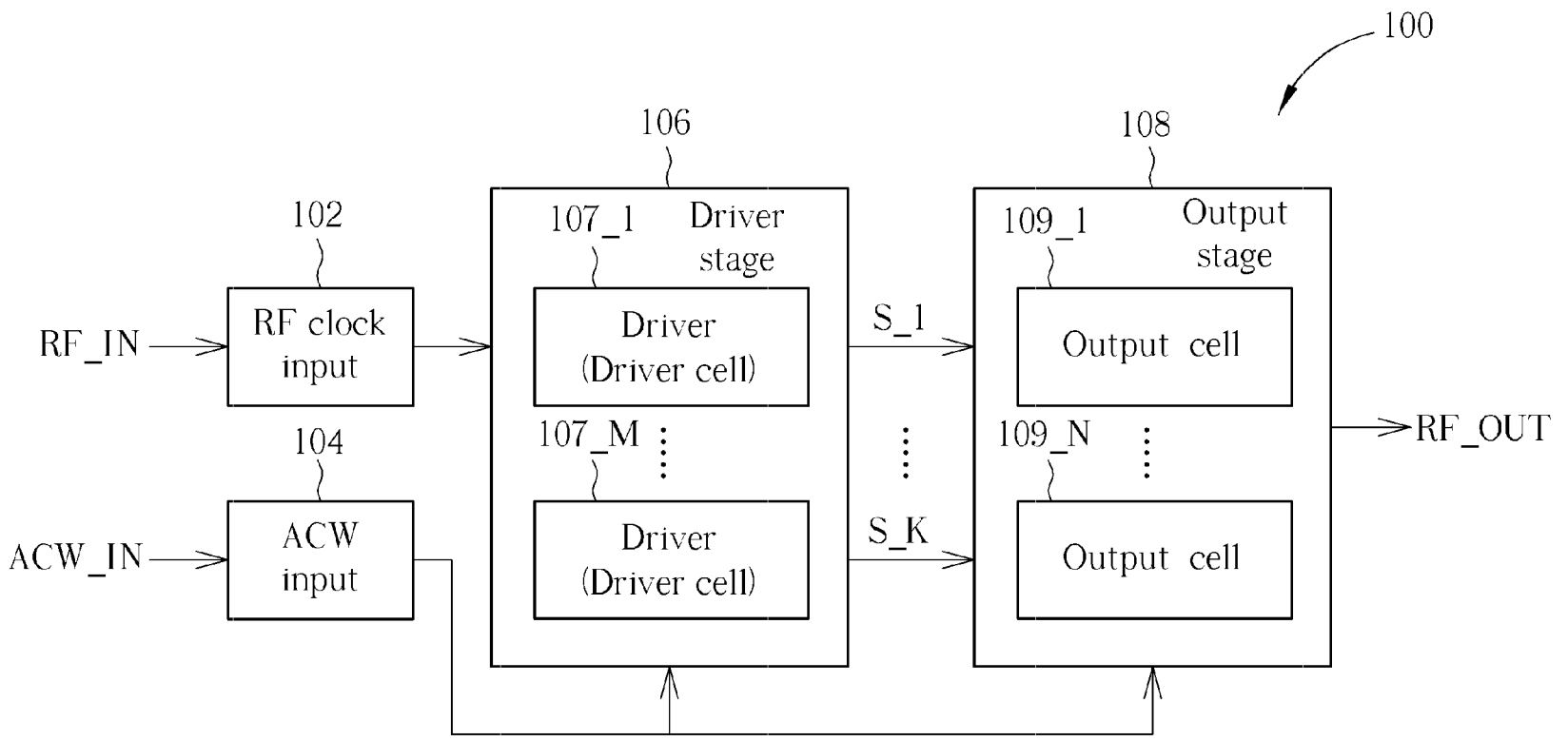

FIG. 1

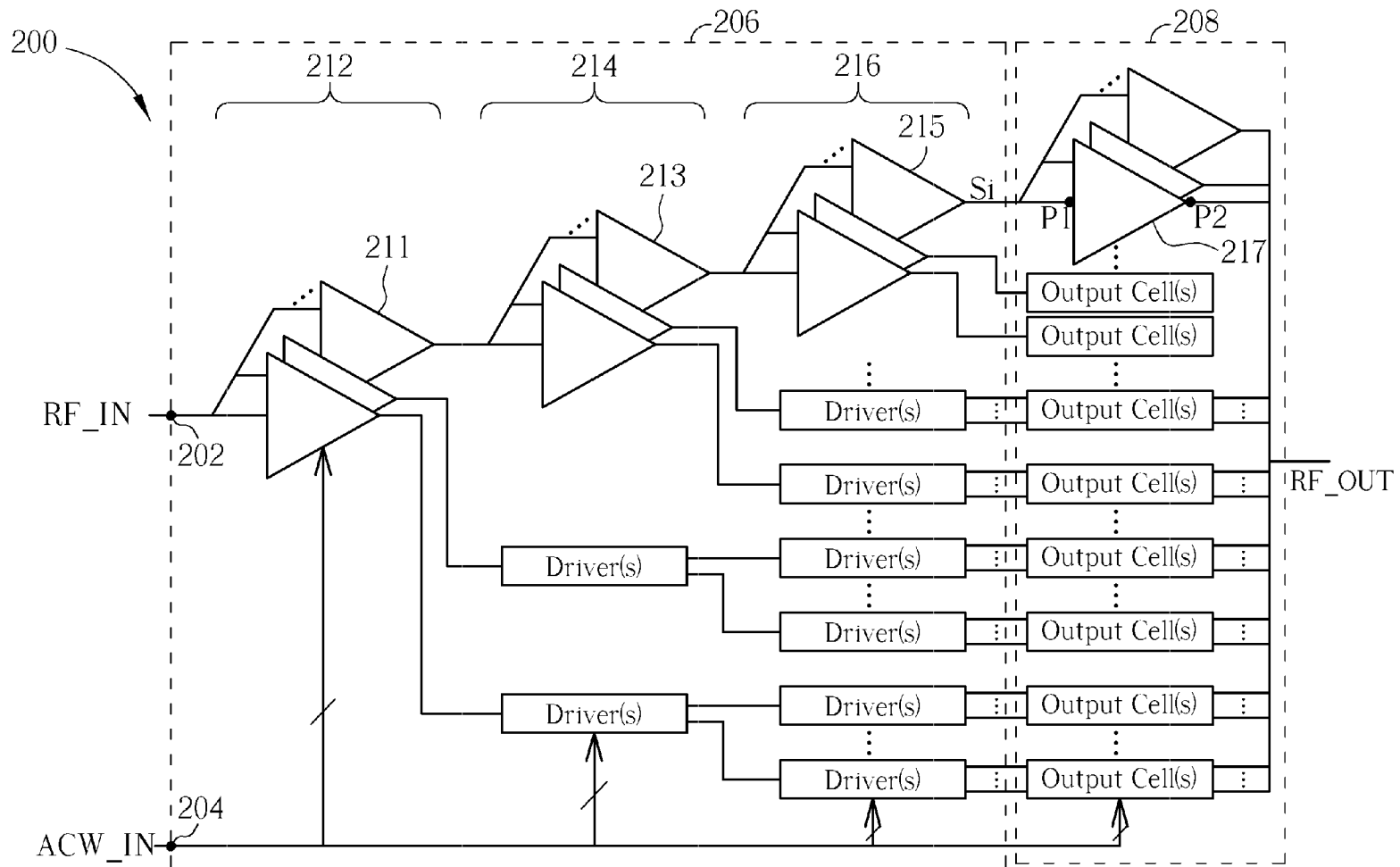

FIG. 2

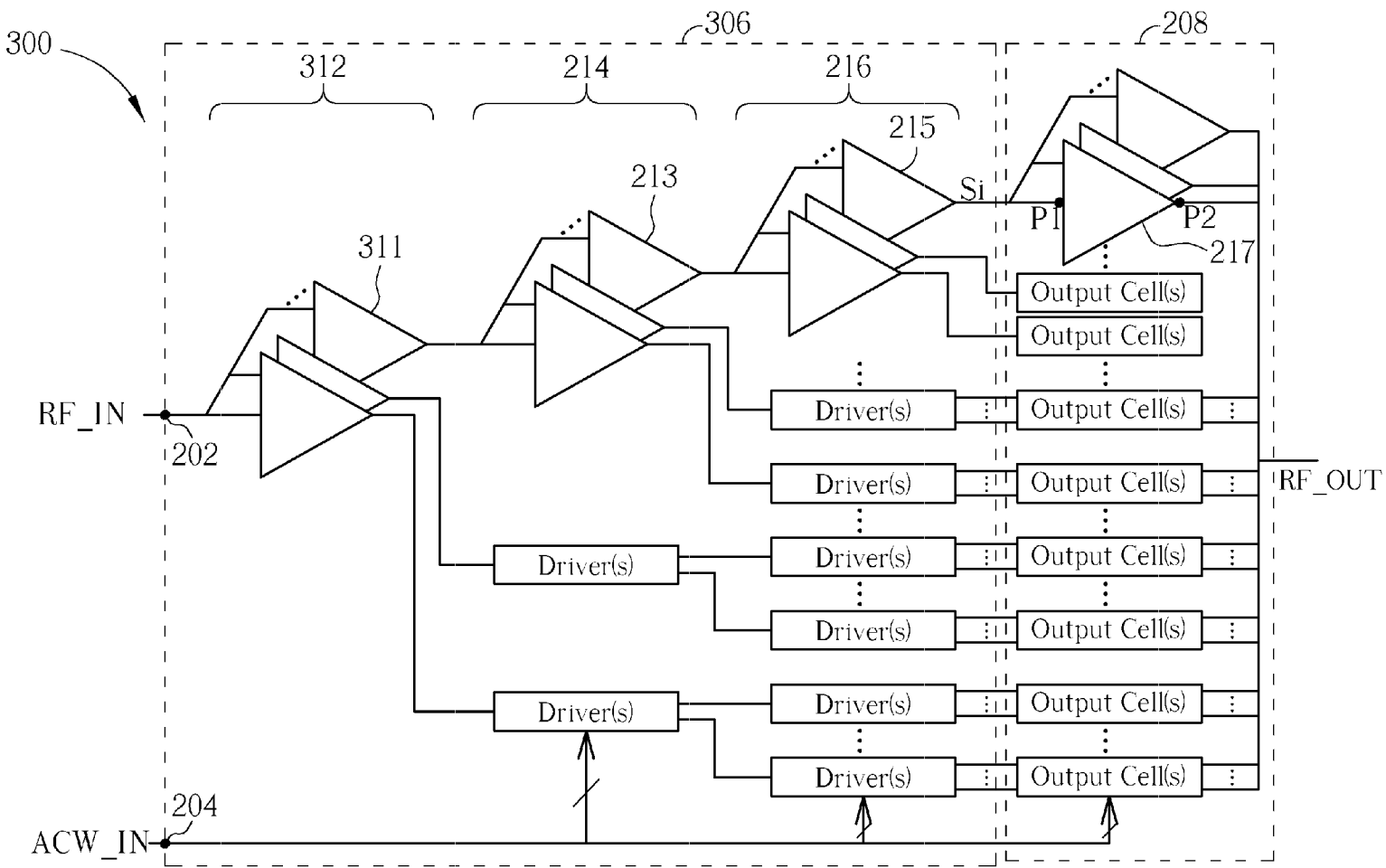

FIG. 3

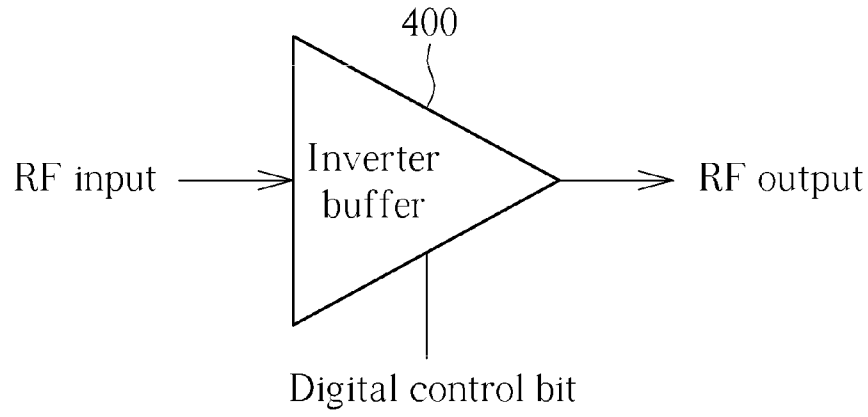

FIG. 4

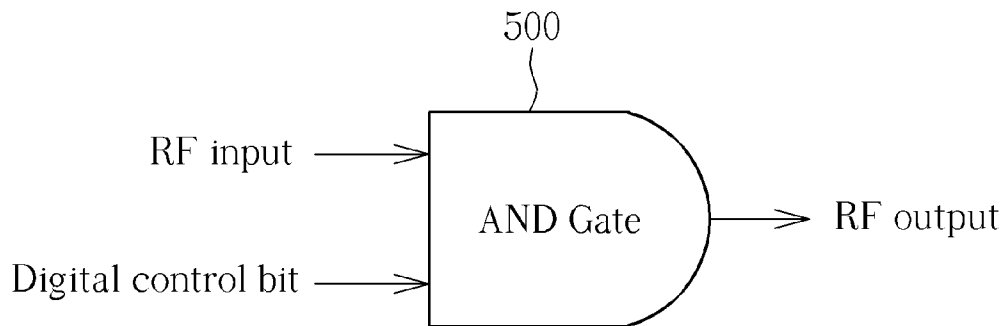

FIG. 5

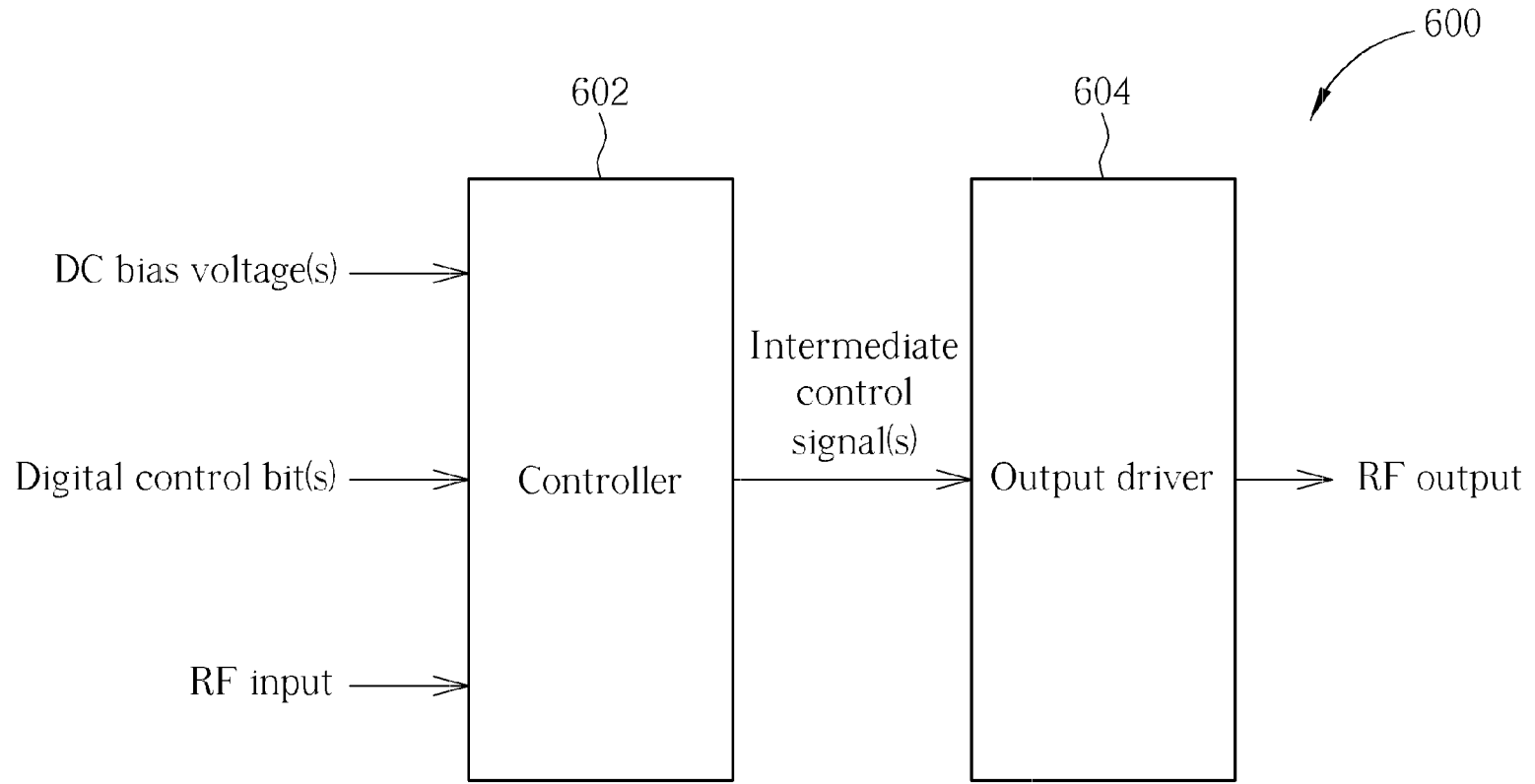

FIG. 6

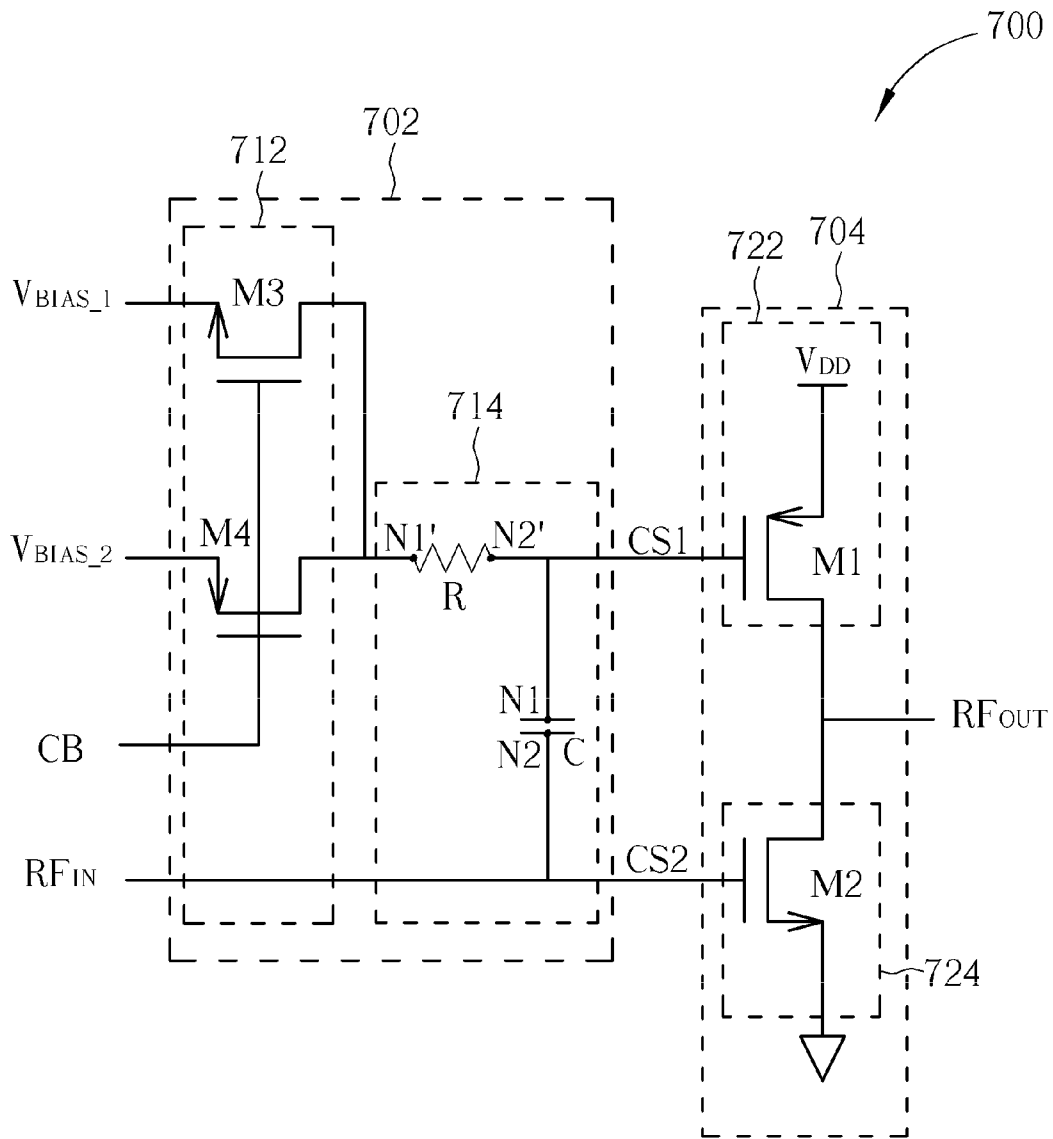

FIG. 7

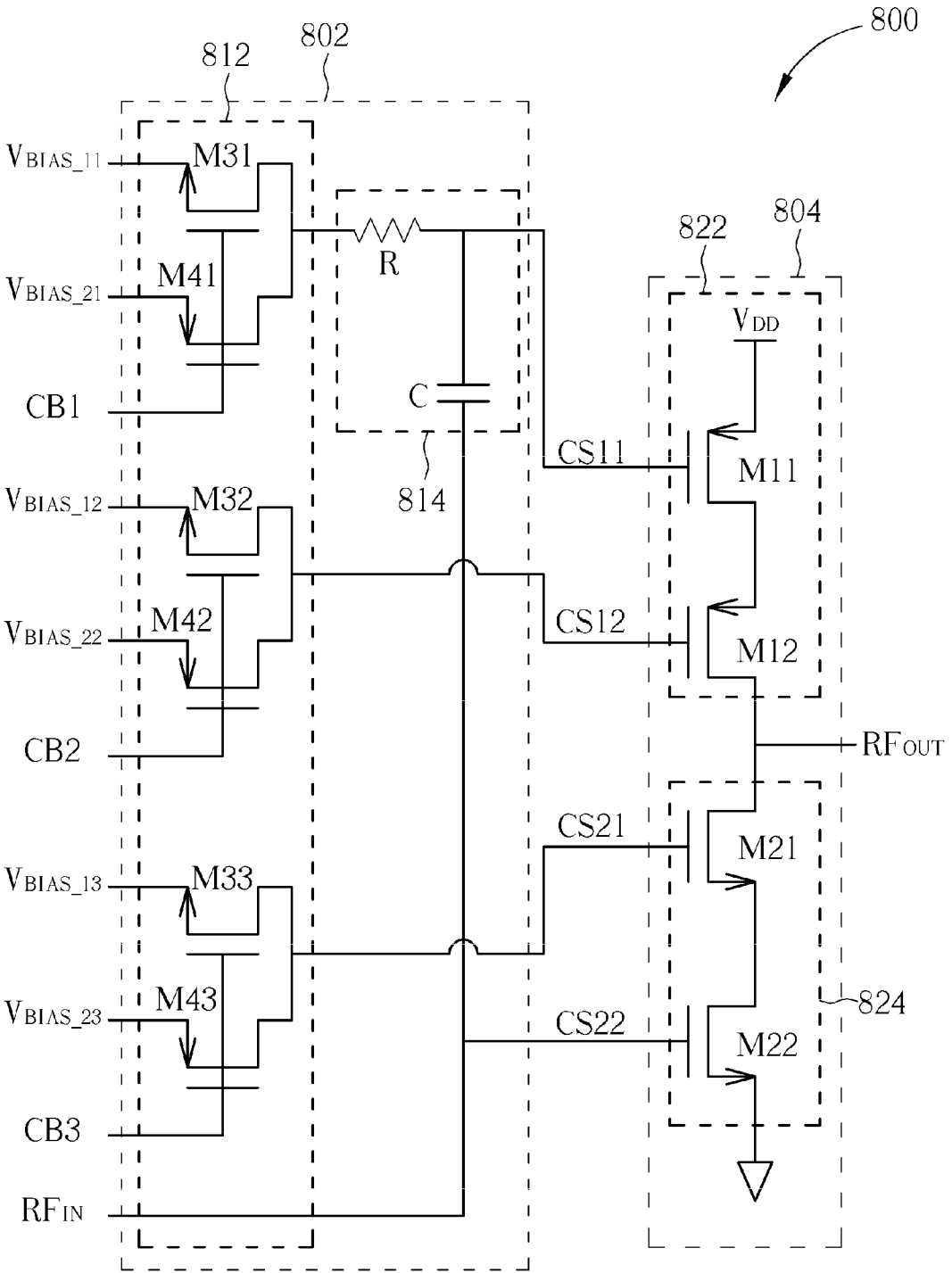

FIG. 8



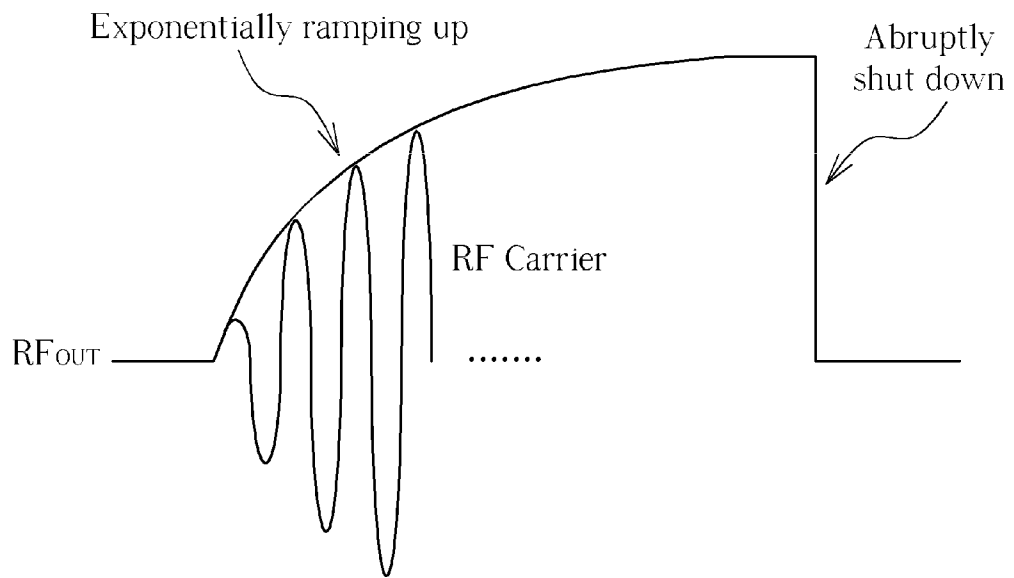

FIG. 9

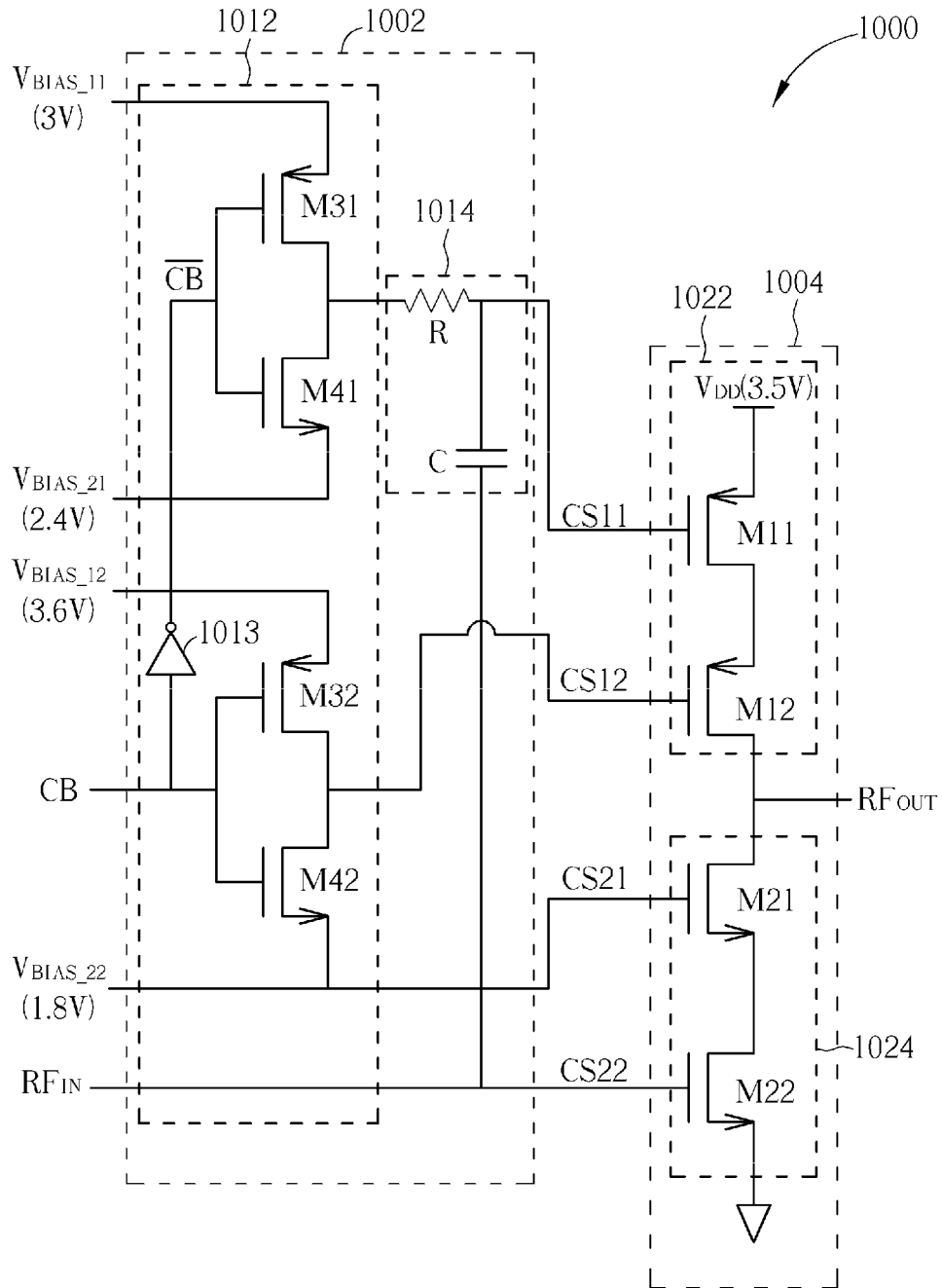

FIG. 10

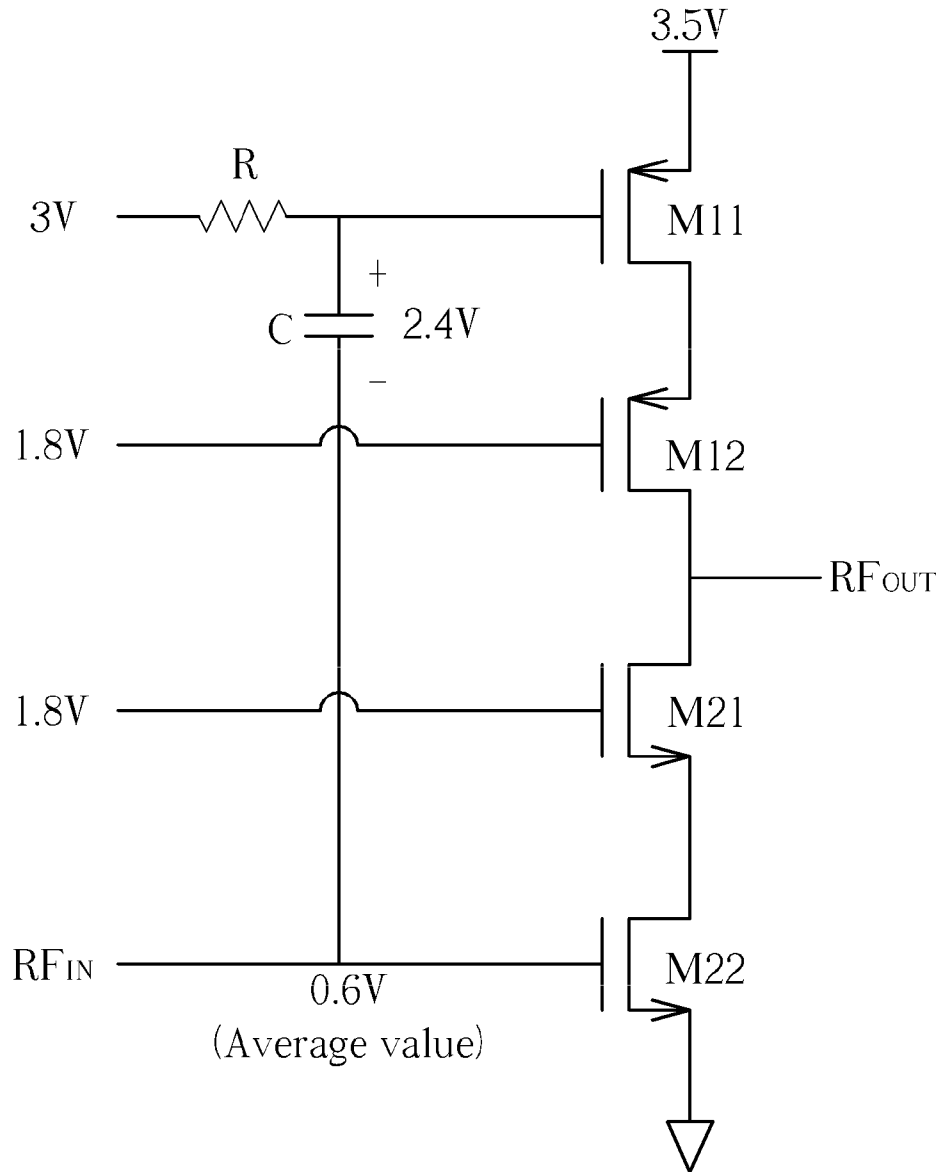

FIG. 11

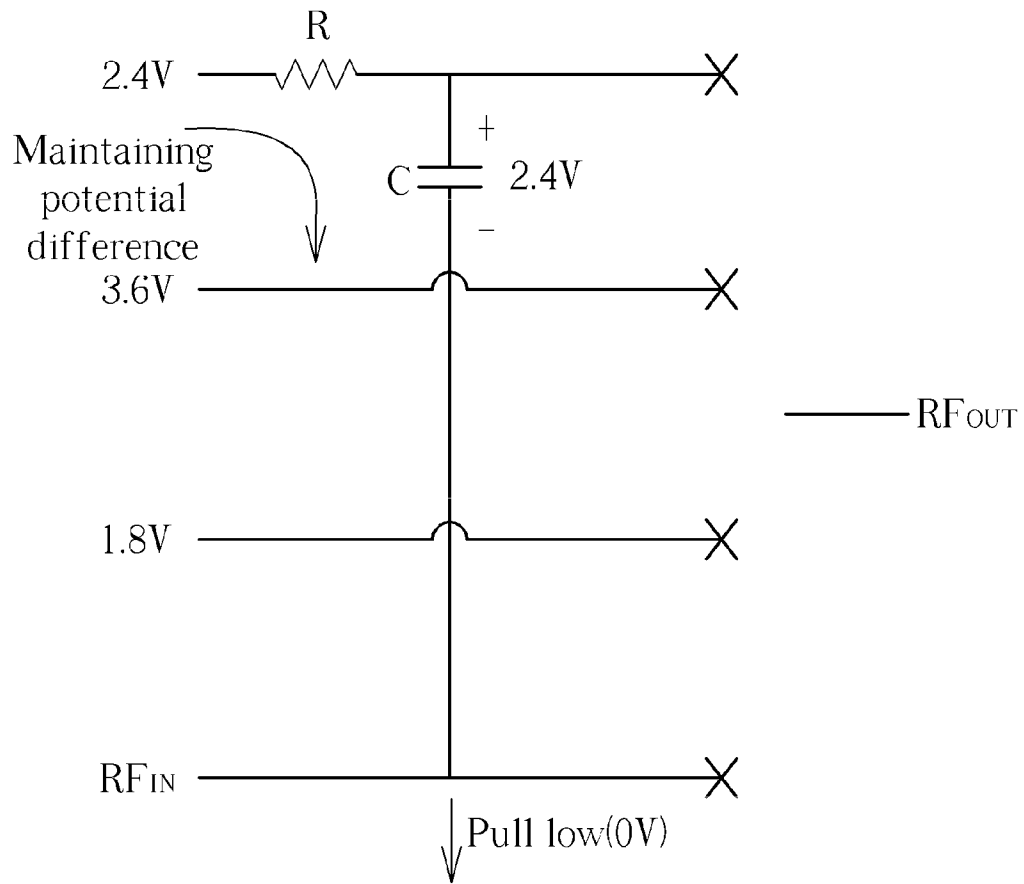

FIG. 12

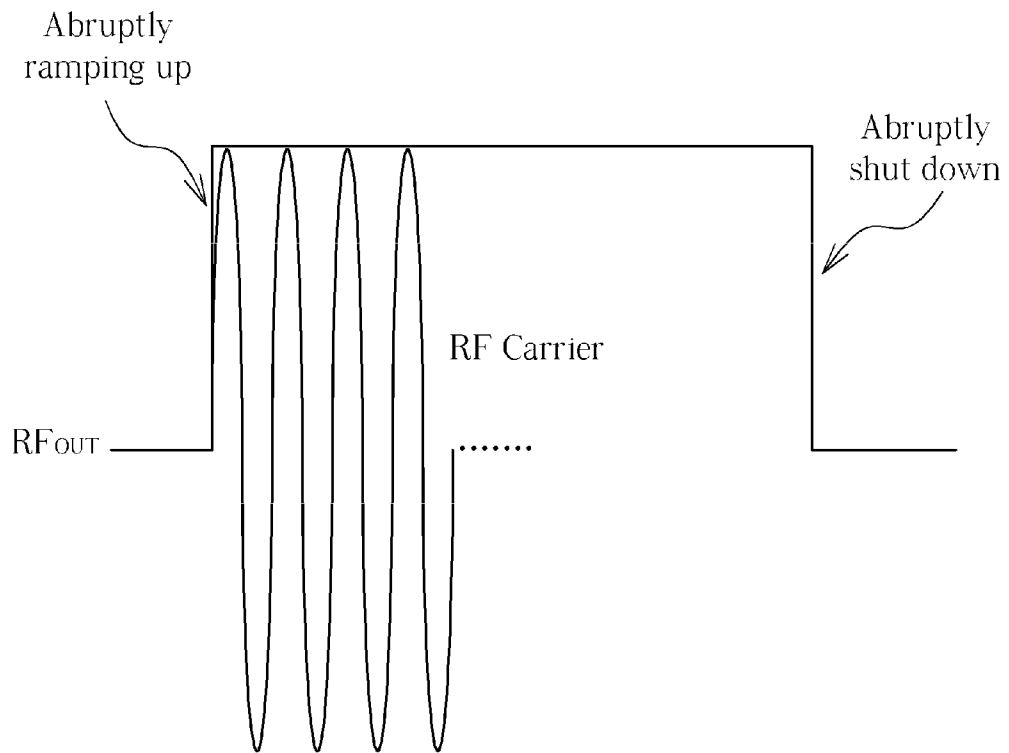

FIG. 13

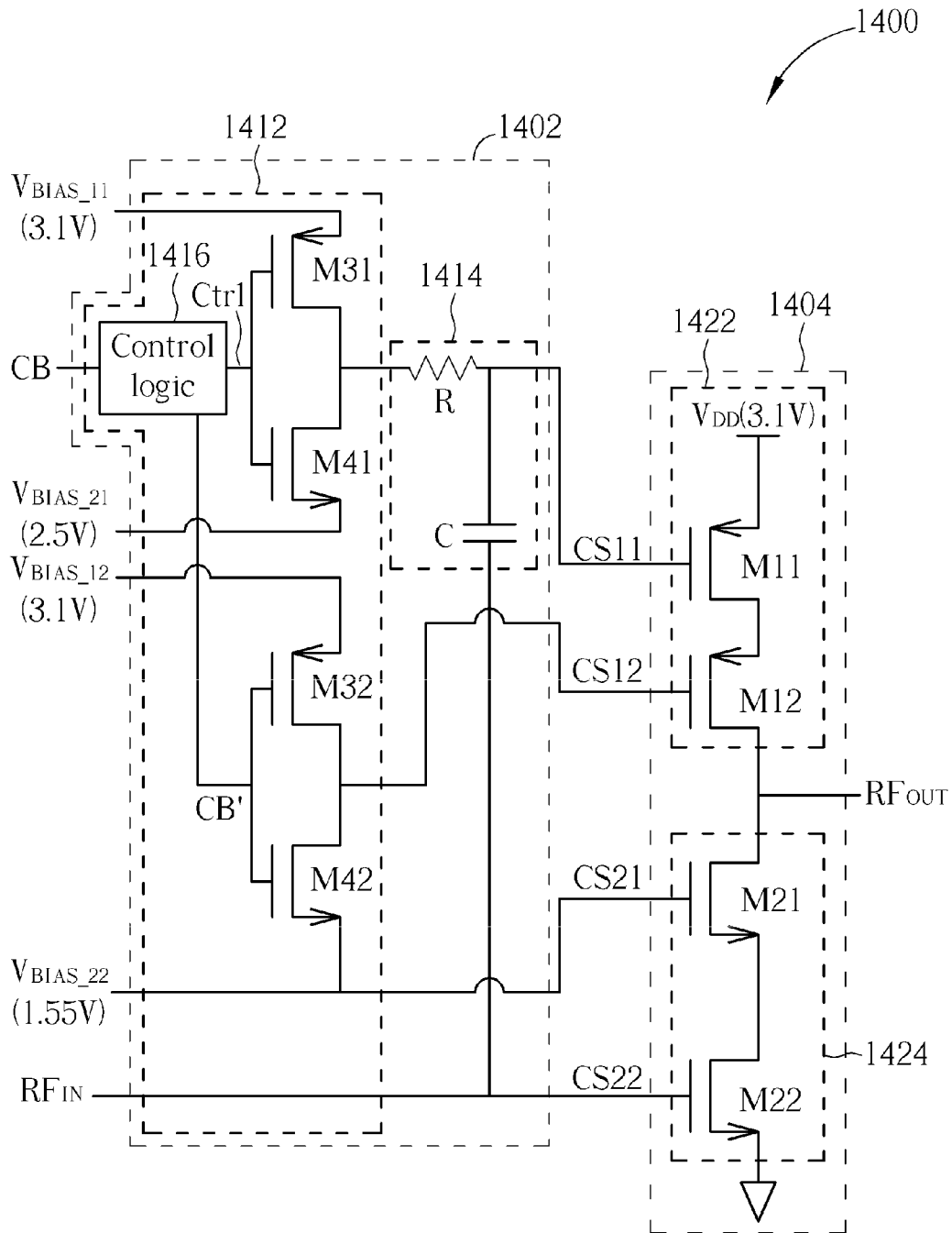

FIG. 14

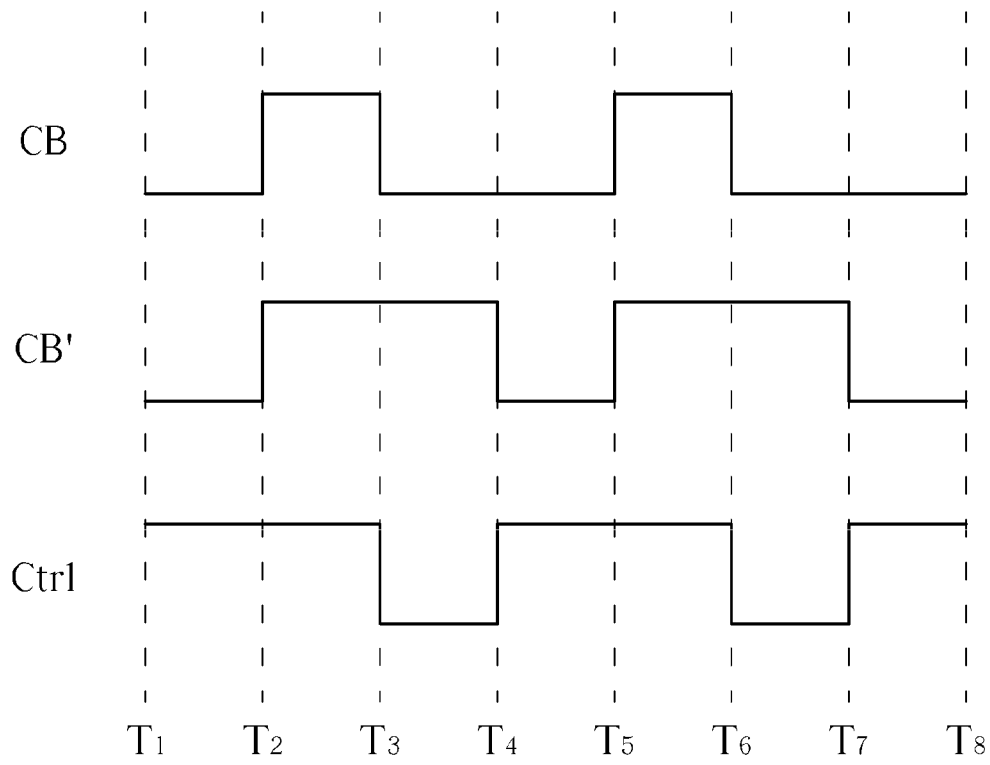

FIG. 15

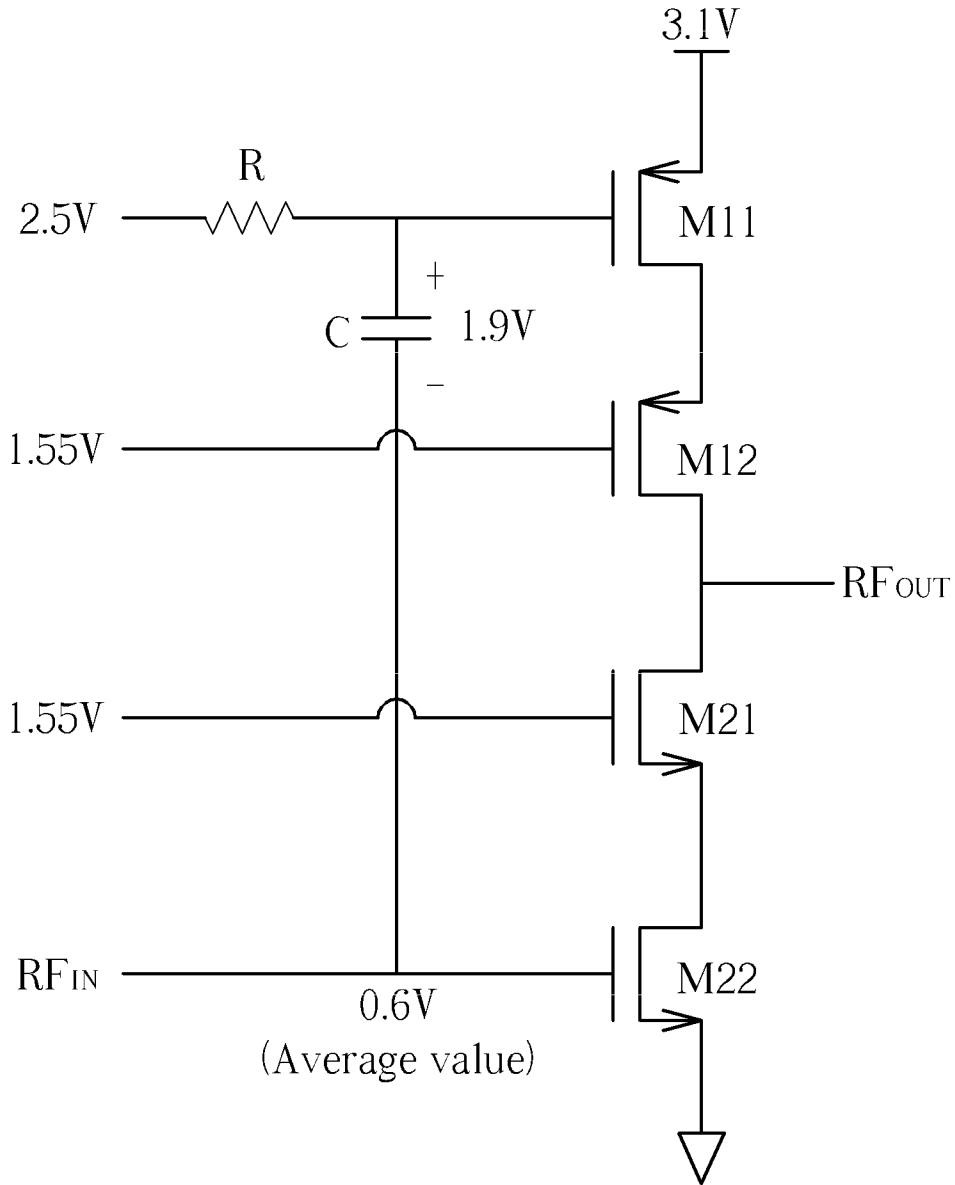

FIG. 16



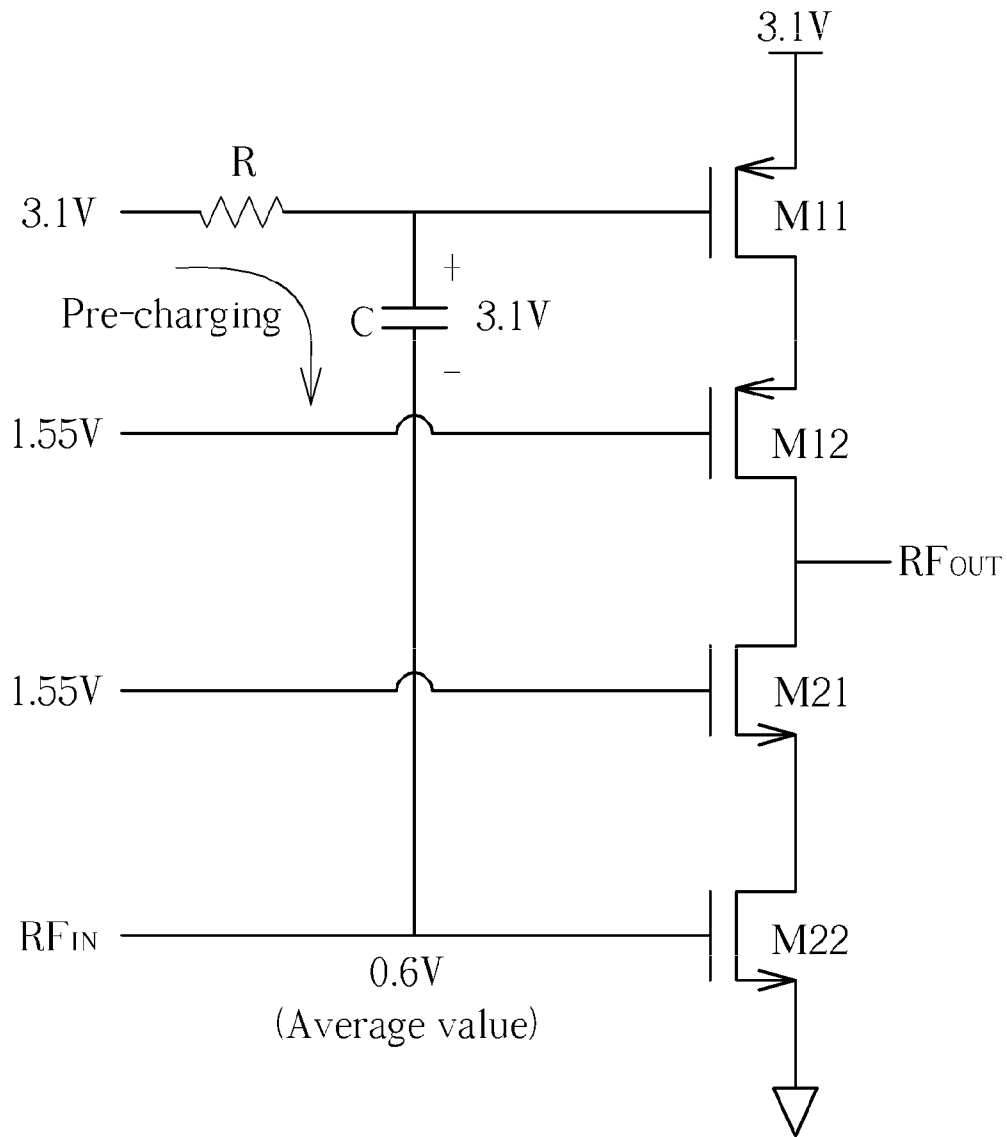

FIG. 17

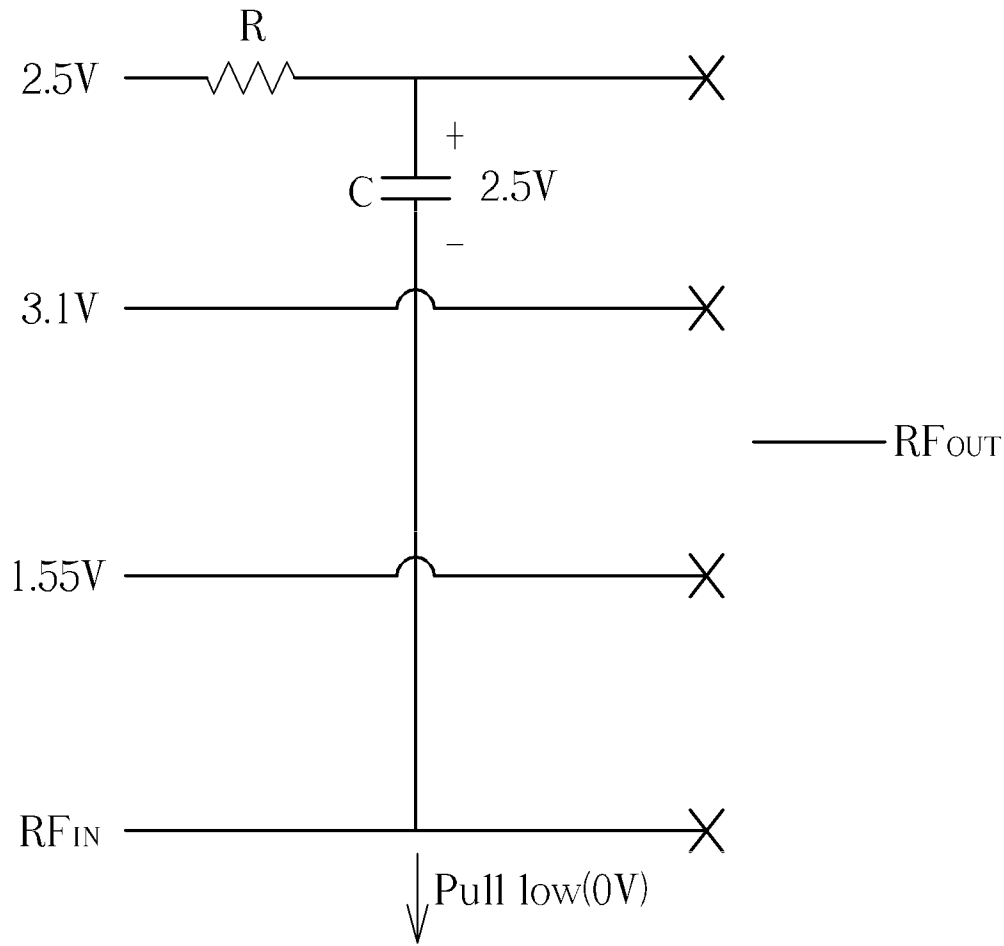

FIG. 18

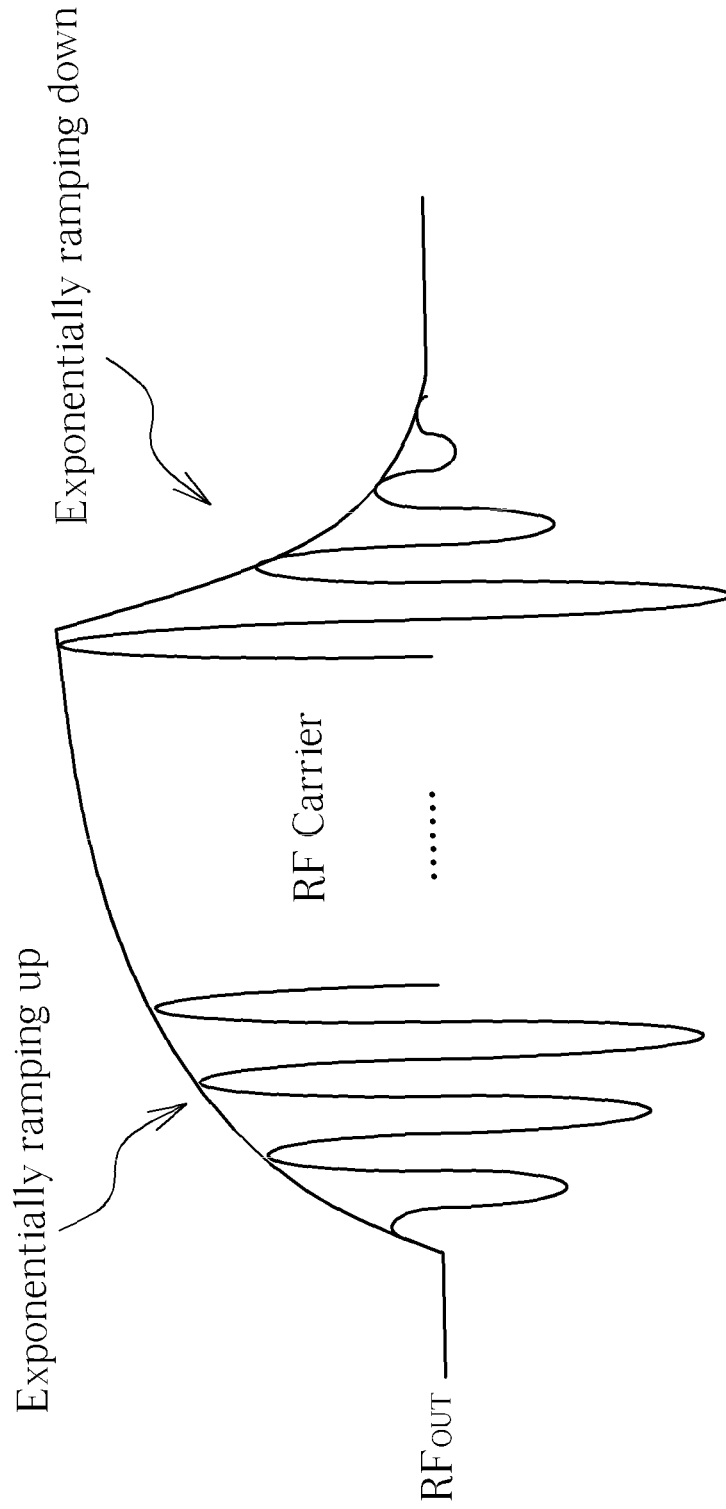

FIG. 19

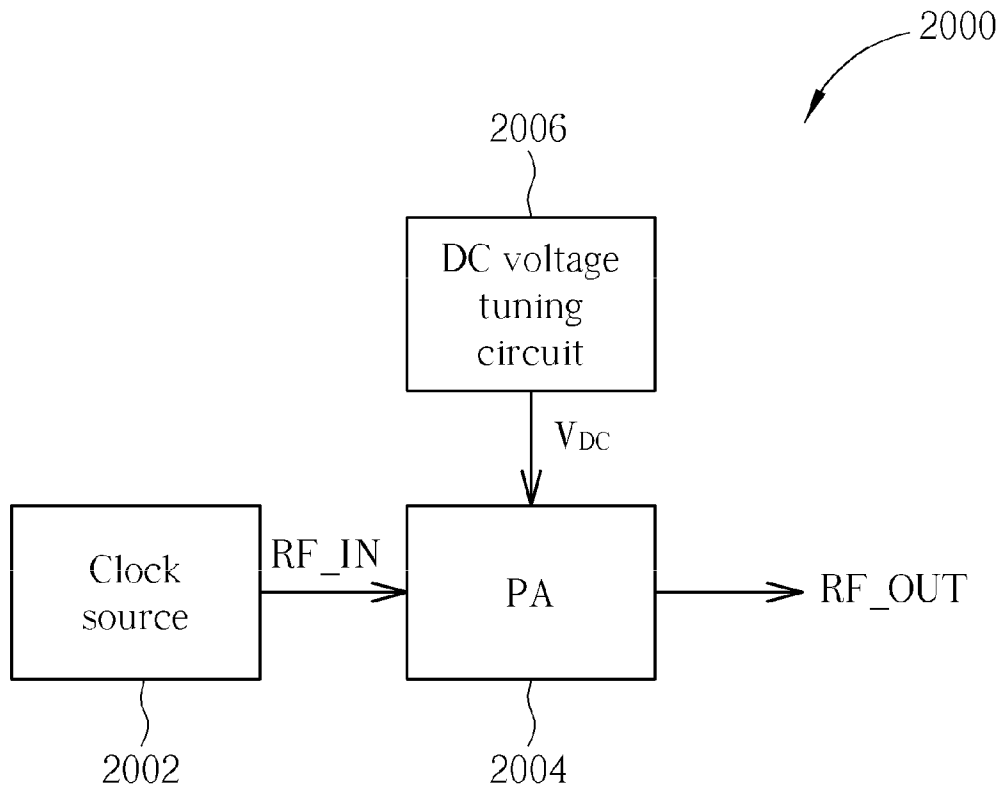

FIG. 20

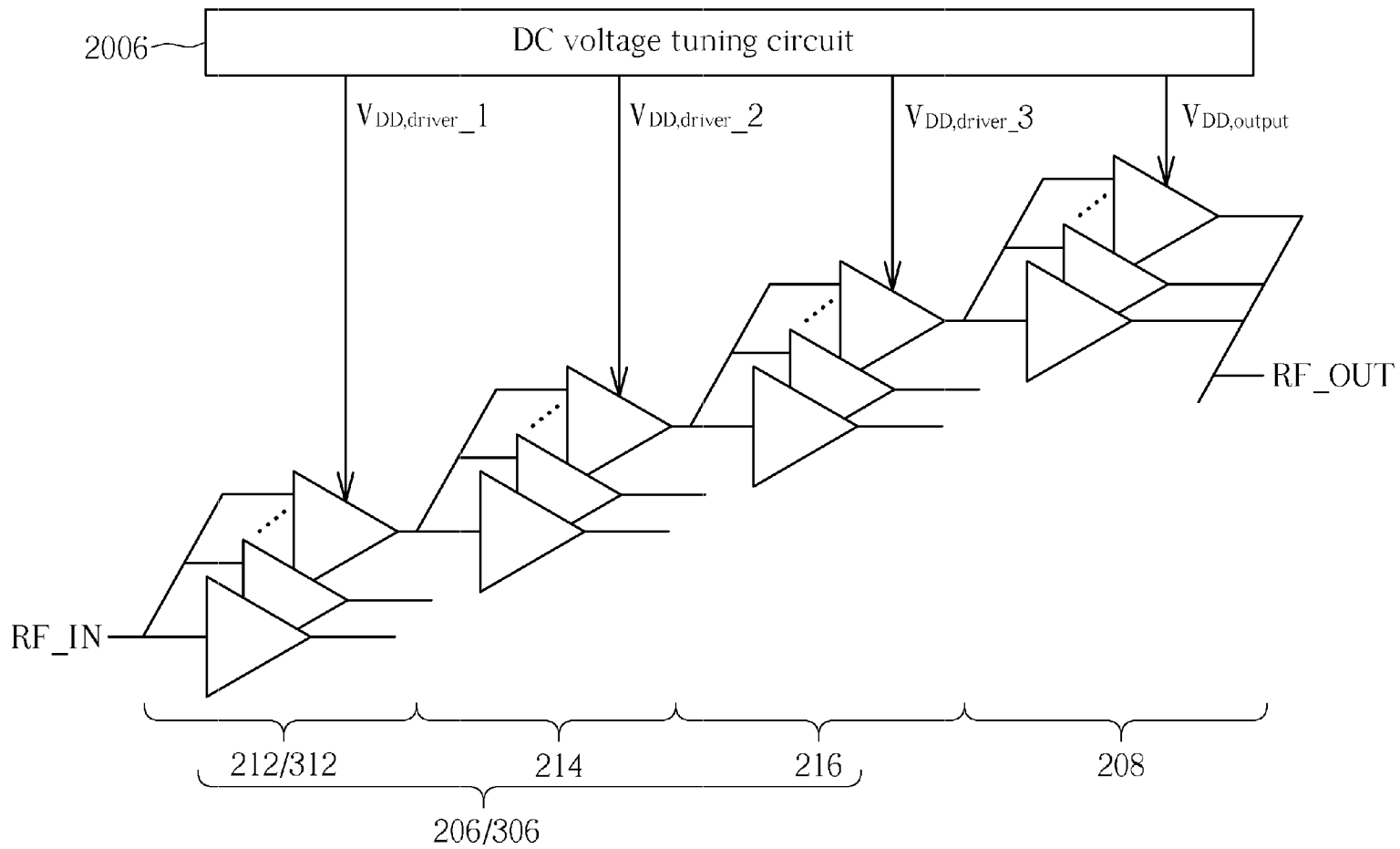

FIG. 21

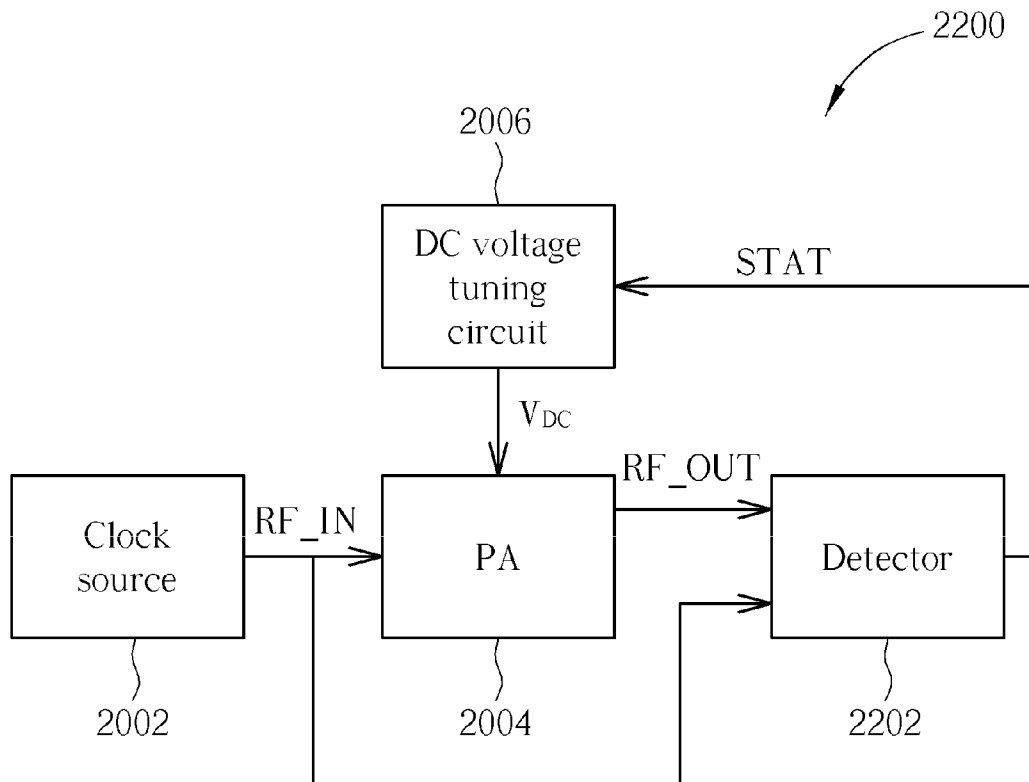

FIG. 22

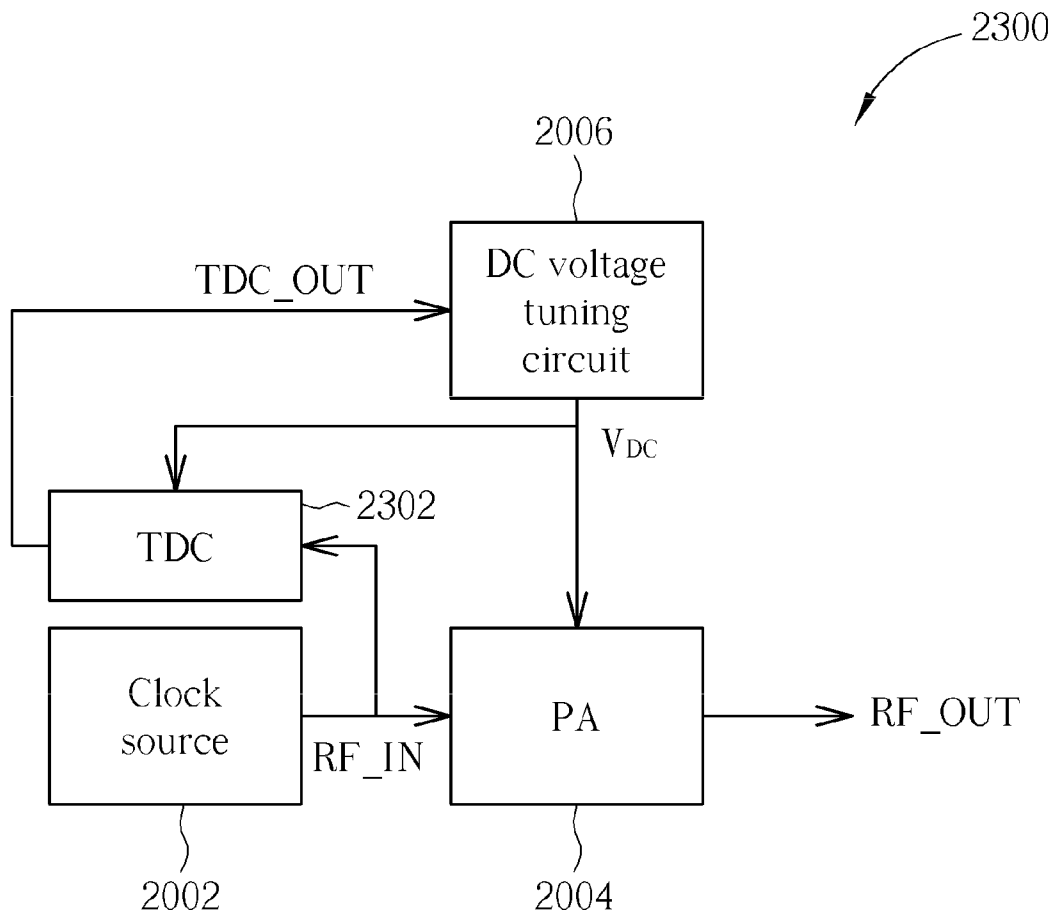

FIG. 23

1

**DIGITALLY-CONTROLLED POWER  
AMPLIFIER WITH BANDPASS  
FILTERING/TRANSIENT WAVEFORM  
CONTROL AND RELATED  
DIGITALLY-CONTROLLED POWER  
AMPLIFIER CELL**

CROSS REFERENCE TO RELATED  
APPLICATIONS

This application claims the benefit of U.S. provisional application No. 61/548,095, filed on Oct. 17, 2011 and incorporated herein by reference.

BACKGROUND

The disclosed embodiments of the present invention relate to power amplification, and more particularly, to a digitally-controlled power amplifier with bandpass filtering/transient waveform control and related digitally-controlled power amplifier cell.

A polar transmitter offers some advantages, such as a potential for reducing complexity and current consumption in the modulator path as well as eliminating the problem of image rejection, thus the polar transmitter is more suitable for implementation in advanced complementary metal oxide semiconductor (CMOS) processing technologies. More specifically, the polar transmitter is a transmitting device that splits a complex baseband signal explicitly represented by an amplitude-modulated (AM) contented component and a phase-modulated (PM) contented component, instead of an explicit in-phase component and a quadrature component. These two orthogonal components are then recombined into a radio-frequency (RF) output signal to be transmitted over the air.

An all-digital radio-frequency (RF) transmitter front-end circuit may be employed by the polar transmitter to enhance power efficiency, reduce the hardware cost and reduce the chip size. One conventional implementation of the all-digital RF transmitter front-end circuit is a digitally-controlled power amplifier (DPA), acting as an RF digital-to-analog converter (RF-DAC). The DPA may include a plurality of DPA cells for combining the AM signal and the PM signal and delivering an integral signal having a desired RF carrier frequency and a required power level. Therefore, how to arrange and control these DPA cells to achieve the desired DPA functionality is a significant concern in the pertinent field.

Regarding a conventional design of a DPA cell, a high-efficiency switching-mode (inverse class-D/class-E) power amplifier is employed. However, current switching-mode DPAs are inductor-loaded. Thus, due to the inherent characteristics of the inductor-loaded switching-mode amplifier, the voltage swing will be greater than  $\pi \times V_{DD}$ , where  $V_{DD}$  is the supply voltage. To reduce the voltage swing, a lower supply voltage  $V_{DD}$  must be used. For example, a DC-DC converter and/or a low-dropout (LDO) regulator may be used to convert a high DC voltage provided by a battery into a low supply voltage  $V_{DD}$  needed by the DPA. Unfortunately, the battery efficiency would be degraded due to the power conversion.

Besides, the AM sampling using a periodic sampling clock would introduce out-of-band (OOB) noise/replica. One conventional solution to reduce the OOB noise/replica is to use a higher sampling rate. However, this would lead to larger power consumption. Another conventional solution is to use a higher digital-to-analog converter (DAC) resolution. However, this would have layout and physical limit. Yet another

2

conventional solution is to use an RF bandpass filter. However, such an RF bandpass filter has a low quality factor and consumes a large area.

Thus, there is also a need for an innovative DPA cell design which has improved efficiency and can effectively reduce the undesired OOB noise/replica.

Moreover, due to the feedback path established by magnetic coupling and/or direct coupling (e.g., coupling via the printed circuit board (PCB) ground and/or the package ground), the transmitter output may be fed back to a clock source in the transmitter, which may degrade the transmitter performance. Thus, there is also a need for a pulling mitigation mechanism employed to improve the transmitter performance.

SUMMARY

In accordance with exemplary embodiments of the present invention, a digitally-controlled power amplifier with bandpass filtering/transient waveform control and related digitally-controlled power amplifier cell are proposed.

According to a first aspect of the present invention, an exemplary digitally-controlled power amplifier (DPA) with bandpass filtering is disclosed. The exemplary DPA includes a radio-frequency (RF) clock input, an amplitude control word (ACW) input, and a plurality of DPA cells. The RF clock input is arranged for receiving an RF clock. The ACW input is arranged for receiving a digital ACW signal. The DPA cells are coupled to the RF clock and the digital signal, wherein at least one of the DPA cells is gradually turned on and off in response to at least one bit of the digital signal.

According to a second aspect of the present invention, an exemplary digitally-controlled power amplifier (DPA) with transient waveform control is disclosed. The exemplary DPA includes a radio-frequency (RF) clock input, an amplitude control word (ACW) input, and a plurality of DPA cells. The RF clock input is arranged for receiving an RF clock. The ACW input is arranged for receiving a digital ACW signal. The DPA cells are coupled to the RF clock and the digital signal, wherein at least one of said DPA cells is abruptly turned on and off in response to at least one bit of said digital ACW signal.

According to a third aspect of the present invention, an exemplary digitally-controlled power amplifier (DPA) cell is disclosed. The exemplary DPA cell includes a controller and an output driver. The controller is arranged for generating a plurality of intermediate control signals according to a plurality of bias voltages, a radio-frequency (RF) input, and a bit of a digital amplitude control word (ACW) signal. The output driver is arranged for generating an RF output according to said intermediate control signals. The output driver includes a P-type block, having at least a P-type MOS transistor responsive to a first intermediate control signal of said intermediate control signals; and an N-type block, having at least an N-type MOS transistor responsive to a second intermediate control signal of said intermediate control signals.

These and other objectives of the present invention will no doubt become obvious to those of ordinary skill in the art after reading the following detailed description of the preferred embodiment that is illustrated in the various figures and drawings.

BRIEF DESCRIPTION OF THE DRAWINGS

FIG. 1 is a block diagram illustrating a generalized structure of a multi-stage digitally-controlled power amplifier (DPA) according to an exemplary embodiment of the present invention.



FIG. 2 is a diagram illustrating a first implementation of a multi-stage DPA according to an embodiment of the present invention.

FIG. 3 is a diagram illustrating a second implementation of a multi-stage DPA according to an embodiment of the present invention.

FIG. 4 is a diagram illustrating an inverter buffer according to an embodiment of the present invention.

FIG. 5 is a diagram illustrating an AND gate according to an embodiment of the present invention.

FIG. 6 is a diagram illustrating an output cell employed in an output stage of a multi-stage DPA according to an exemplary embodiment of the present invention.

FIG. 7 is a diagram illustrating a first circuit implementation of the output cell shown in FIG. 6 according to an exemplary embodiment of the present invention.

FIG. 8 is a diagram illustrating a second circuit implementation of the output cell shown in FIG. 6 according to an exemplary embodiment of the present invention.

FIG. 9 is a diagram illustrating a time-domain waveform of a single bit operation of the output cell shown in FIG. 7.

FIG. 10 is a diagram illustrating a third circuit implementation of the output cell shown in FIG. 6 according to an exemplary embodiment of the present invention.

FIG. 11 is a diagram illustrating an equivalent circuit of the output driver shown in FIG. 10 that is operating in an ON state.

FIG. 12 is a diagram illustrating an equivalent circuit of the output driver shown in FIG. 10 that is operating in an OFF state.

FIG. 13 is a diagram illustrating a time-domain waveform of a single bit operation of the output cell shown in FIG. 10.

FIG. 14 is a diagram illustrating a fourth circuit implementation of the output cell shown in FIG. 6 according to an exemplary embodiment of the present invention.

FIG. 15 is a waveform diagram of the digital control bit and the control outputs according to an exemplary embodiment of the present invention.

FIG. 16 is a diagram illustrating an equivalent circuit of the output driver shown in FIG. 14 that is operating in an ON state.

FIG. 17 is a diagram illustrating an equivalent circuit of the output driver shown in FIG. 14 that is operating in a pre-charging state.

FIG. 18 is a diagram illustrating an equivalent circuit of the output driver shown in FIG. 14 that is operating in an OFF state.

FIG. 19 is a diagram illustrating a time-domain waveform of a single bit operation of the output cell shown in FIG. 14.

FIG. 20 is a diagram illustrating a transmitter employing an exemplary pulling mitigation mechanism according to an embodiment of the present invention.

FIG. 21 is a diagram illustrating a multi-stage DPA with supply voltages tuned by a DC voltage tuning circuit for pulling mitigation of a clock source.

FIG. 22 is a diagram illustrating a transmitter employing another exemplary pulling mitigation mechanism according to an embodiment of the present invention.

FIG. 23 is a diagram illustrating a transmitter employing yet another exemplary pulling mitigation mechanism according to an embodiment of the present invention.

#### DETAILED DESCRIPTION

Certain terms are used throughout the description and following claims to refer to particular components. As one skilled in the art will appreciate, manufacturers may refer to a

component by different names. This document does not intend to distinguish between components that differ in name but not function. In the following description and in the claims, the terms “include” and “comprise” are used in an open-ended fashion, and thus should be interpreted to mean “include, but not limited to . . .”. Also, the term “couple” is intended to mean either an indirect or direct electrical connection. Accordingly, if one device is electrically connected to another device, that connection may be through a direct electrical connection, or through an indirect electrical connection via other devices and connections.

FIG. 1 is a block diagram illustrating a generalized structure of a multi-stage digitally-controlled power amplifier (DPA) according to an exemplary embodiment of the present invention. The exemplary multi-stage DPA 100 includes, but is not limited to, a radio-frequency (RF) clock input 102, an amplitude control word (ACW) input 104, a driver stage 106 having a plurality of drivers (i.e., driver cells) 107\_1-107\_M included therein, and an output stage 108 having a plurality of output cells 109\_1-109\_N included therein. The RF clock input 102 is arranged for receiving an RF clock RF\_IN. For example, the RF clock RF\_IN is a phase-contented (PM) signal in a polar transmitter, and therefore carries phase-related information. The ACW input 104 is arranged for receiving a digital ACW signal (e.g., a digital control word) ACW\_IN. For example, the digital ACW signal ACW\_IN is an amplitude-contented (AM) signal in a polar transmitter, and therefore carries amplitude-related information. The drivers 107\_1-107\_M are coupled to the RF clock RF\_IN, and arranged for producing a plurality of intermediate signals S\_1-S\_K. Regarding the output stage 108, it is coupled to the driver stage 106 for receiving the intermediate signals S\_1-S\_K and producing an output signal RF\_OUT according to the received intermediate signals S\_1-S\_K.

In this exemplary design, at least one of the drivers 107\_1-107\_M is responsive to at least one bit of the digital ACW signal ACW\_IN, and/or at least one of the output cells 109\_1-109\_N is responsive to at least one bit of the digital ACW signal. That is, at least one of the drivers 107\_1-107\_M is controlled according to at least one bit of the digital ACW signal ACW\_IN, and/or at least one of the output cells 109\_1-109\_N is controlled according to at least one bit of the digital ACW signal. By way of example, but not limitation, one or more output cells may be directly controlled by bit(s) of the digital ACW signal ACW\_IN, or may be controlled by control bit(s) derived from processing bit(s) of the digital ACW signal ACW\_IN.

In one exemplary design, the DPA cells 107\_1-107\_M and 109\_1-109\_N included in the driver stage 106 and the output stage 108 may be arranged in a tree topology or a chain topology, depending upon the interconnections among the DPA cells. Please refer to FIG. 2, which is a diagram illustrating a first implementation of a multi-stage DPA according to an embodiment of the present invention. The multi-stage DPA 200 is based on the hardware configuration shown in FIG. 1, and therefore has a driver stage 206 and an output stage 208, where the driver stage 206 receives an RF clock RF\_IN (e.g., a PM signal) from an RF clock input 202, and the output stage 208 receives an ACW input ACW\_IN from an ACW input 204. The driver stage 206 has a plurality of cascaded stages 212, 214 and 216. It should be noted that the number of the cascaded stages employed in the driver stage 206 is for illustrative purposes only. The stage 212 includes a plurality of drivers 211, the stage 214 includes a plurality of drivers 213, and the stage 216 includes a plurality of drivers 215. Each driver 211 in stage 212 may be coupled to one or more drivers 213 in the next stage 214. Besides, the number of

5

drivers **213** coupled to one driver **211** may be equal to or different from the number of drivers **213** coupled to another driver **211**, depending upon actual design requirement/consideration. In a case where a tree topology is employed, the number of drivers **213** coupled to one driver **211** may be greater than one.

Similarly, each driver **213** in the stage **214** may be coupled to one or more drivers **215** in the next stage **216**. Besides, the number of drivers **215** coupled to one driver **213** may be equal to or different from the number of drivers **215** coupled to another driver **213**, depending upon actual design requirement/consideration. In a case where a tree topology is employed, the number of drivers **215** coupled to one driver **213** may be greater than one.

Regarding the output stage **208**, it includes a plurality of output cells **217**. Each driver **215** in the driver stage **206** is coupled to one or more output cells **217** in the output stage **208**. As shown in FIG. 2, each output cell **217** has an input port P1 and an output port P2. The input port P1 is coupled to one of the intermediate signals  $S_i$ , generated from the drivers **215** located at the last stage **216**. Output ports P2 of all output cells **217** are coupled to each other (directly, as shown here, although an indirect coupling could also be used) such that the output signal RF\_OUT is derived from a summation of signal outputs of enabled output cells **217**. In a case where a tree topology, the number of output cells **217** coupled to one driver **215** may be greater than one.

By way of example, but not limitation, all of the drivers **211**, **213**, **215** and output cells **217** shown in FIG. 2 may be configured to be responsive to the digital ACW signal ACW\_IN for controlling the power level of the output signal RF\_OUT. Hence, the discrete drivers **211**, **213**, **215** included in the driver stage **206** may be controlled independently, and the discrete output cells **217** included in the output stage **208** may be controlled independently. As mentioned above, the driver stage **206** is used to couple the phase-contented and amplitude-contented RF carrier to the output stage **208**, and the output stage **208** is used to deliver the integral signal at the RF carrier frequency and required power level. Hence, with proper setting of bits transmitted via the digital ACW signal ACW\_IN, the power of the output signal RF\_OUT would be set to the required power level.

In the example shown in FIG. 2, all of the drivers **211**, **213**, **215** and output cells **217** included in the multi-stage DPA **200** are responsive to the digital ACW signal ACW\_IN. However, this is for illustrative purposes only, and is not meant to be a limitation of the present invention. Please refer to FIG. 3, which is a diagram illustrating a second implementation of a multi-stage DPA according to an embodiment of the present invention. The multi-stage DPA **300** is also based on the hardware configuration shown in FIG. 1. The major difference between the multi-stage DPAs **200** and **300** is that at least one of drivers directly connected to the RF clock input **202** is not responsive to any bit of the digital ACW signal ACW\_IN. By way of example, but not limitation, all of the drivers (i.e., driver cells) **311** disposed at the stage **312** shown in FIG. 3 are not controlled by the digital ACW signal ACW\_IN. In other words, all of the drivers **311** are enabled when the multi-stage DPA **300** is operative to generate the output signal RF\_OUT. One benefit/advantage of such a design is that the load viewed by a preceding circuit component (e.g., a DCO which generates the RF clock RF\_IN) would be constant, thus improving stability and accuracy of the overall transmitter system.

The aforementioned DPA driver cell employed in the driver stage may be simply implemented using an inverter buffer **400**, as shown in FIG. 4. The inverter buffer **400** is arranged to generate an RF output according to an RF input,

6

where a digital control bit decides whether the inverter buffer **400** is enabled or disabled. Alternatively, the aforementioned DPA driver cell employed in the driver stage may be implemented using a logic gate, such as an AND gate **500** shown in FIG. 5. Therefore, the AND gate **500** generates an RF output by mixing an RF input and a digital control bit, where a logic gating operation is controlled by the digital control bit.

The aforementioned DPA output cell employed in the output stage may be simply implemented using the inverter buffer **400** shown in FIG. 4. Therefore, the DPA output cell is directly controlled by the digital control bit. Alternatively, the DPA output cell may be indirectly controlled by the digital control bit. FIG. 6 is a diagram illustrating an output cell employed in an output stage of a multi-stage DPA according to an exemplary embodiment of the present invention. The output cell **600** includes a controller **602** and an output driver **604**. The controller **602** receives one or more DC bias voltages, one or more digital control bits and an RF input, and generates one or more intermediate control signals to the following output driver **604** according to the actual design of the output driver **604**. For example, the output driver **604** may be a class-D amplifier, including a P-type block with P-type transistor(s) and an N-type block with N-type transistor(s). Hence, the controller **602** is configured to generate intermediate control signals to gate terminals of transistors employed in the output driver **604**. The output driver **604** generates an RF output according to intermediate control signal(s).

The DPA driver cell/output cell may be configured in a single-ended topology to meet the requirement of a single-ended application. Alternately, the DPA driver cell/output cell may be configured in a differential topology to meet the requirement of a differential application.

Please note that the main concept of the present invention is to provide an innovative multi-stage arrangement of DPA cells, including driver cells in a driver stage and output cells in an output stage, rather than an implementation of the DPA cell. Any DPA cell design capable of achieving the desired functionality of the driver cell/output cell may be employed to realize the DPA cells employed in the multi-stage DPA **100/200/300**. This also obeys the spirit of the present invention, and falls within the scope of the present invention.

By way of example, but not limitation, the proposed multi-stage DPA **100/200/300** may have one or all of the following features. Each stage is fully operated in a switching mode for highest efficiency. There is no DC level biasing needed. Each unit has a single RF input containing phase information only. Each unit has a single RF output containing phase and partial amplitude information.

Regarding the output cell **600** shown in FIG. 6, several circuit implementations are provided hereinafter for illustrative purposes. FIG. 7 is a diagram illustrating a first circuit implementation of the output cell **600** shown in FIG. 6 according to an exemplary embodiment of the present invention. The output cell **700** includes a controller **702** and an output buffer **704**. The controller **702** is arranged for receiving a plurality of bias voltages  $V_{BIAS\_1}$  and  $V_{BIAS\_2}$ , an RF input  $RF_{IN}$ , and a digital control bit CB (i.e., one bit of a digital ACW signal), and generating a plurality of intermediate control signals CS1 and CS2. In this embodiment, the controller **702** includes a control block **712** and a coupling block **714**. The control block **712** is arranged for controlling the intermediate control signals CS1 and CS2 according to the bias voltages  $V_{BIAS\_1}$  and  $V_{BIAS\_2}$ , the RF input  $RF_{IN}$ , and the digital control bit CB. The output driver **704** is arranged for generating an RF output  $RF_{OUT}$  according to the intermediate control signals CS1 and CS2. In this embodiment, the

output driver **704** has cascoded blocks **722** and **724**, where the block **722** is a P-type block and the block **724** is an N-type block. The P-type block **722** has a P-type metal-oxide-semiconductor (MOS) transistor **M1** responsive to the intermediate control signal **CS1**, and the N-type block **M2** has an N-type MOS transistor **M2** responsive to the intermediate control signal **CS2**.

Regarding the control block **712**, it includes an N-type MOS transistor **M3** and a P-type MOS transistor **M4** both controlled by the digital control bit **CB**. For example, when the N-type MOS transistor **M3** is enabled (i.e., switched on), the P-type MOS transistor **M4** is disabled (i.e., switched off), and when the N-type MOS transistor **M3** is disabled (i.e., switched off), the P-type MOS transistor **M4** is enabled (i.e., switched on). As can be seen from FIG. 7, the DC bias voltage of the MOS transistor **M1** is set by  $V_{BIAS\_1}$  when the MOS transistor **M3** is enabled by the digital control bit **CB** (i.e.,  $CB='1'$ ), and the DC bias voltage of the MOS transistor **M1** is set by  $V_{BIAS\_2}$  when the MOS transistor **M4** is enabled by the digital control bit **CB** (i.e.,  $CB='0'$ ). Besides, the control block **712** directly transmits the RF input  $RF_{IN}$  as the intermediate control signal **CS2**.

The coupling block **714** includes a capacitor **C** and a resistor **R**, where the capacitor **C** has a first end **N1** coupled to gate of the P-type MOS transistor **M1** and a second end **N2** coupled to gate of the N-type MOS transistor **M2**, and the resistor **R** has a first end **N1'** coupled to the preceding control block **712** and a second end **N2'** coupled to the first end **N1** of the capacitor **C**. The capacitor **C** is used for AC coupling such that AC signal components carried by the RF input  $RF_{IN}$  is coupled to the gate of the MOS transistor **M1**. To put it another way, each of the intermediate control signals **CS1** and **CS2** would have AC signal components, and DC levels of the intermediate control signals **CS1** and **CS2** are different. For example, the DC level of the intermediate control signal **CS2** may be 0.6V, whereas the DC level of the intermediate control signal **CS1** is either  $V_{BIAS\_1}$  or  $V_{BIAS\_2}$ .

As can be readily seen from FIG. 7, the output driver **704** is not inductor-loaded. Hence, no class-D<sup>-1</sup>/class-E amplifier is employed in the output cell **700**. By way of example, the output driver **704** is implemented using a class-D amplifier, thus avoiding the voltage swing problem encountered by the conventional class-D<sup>-1</sup>/class-E DPA cell structure. Specifically, the voltage swing of the output cell **700** is limited within the  $V_{DD}$  rail. The supply voltage  $V_{DD}$  of the output cell **700** is therefore allowed to be increased to approach the nominal voltage value of the battery, which improves the battery efficiency accordingly. Besides, as the voltage swing of the output cell **700** is limited within the  $V_{DD}$  rail, reliability of core devices and I/O devices are ensured.

The number of P-type MOS transistors included in the P-type block **722** shown in FIG. 7 and the number of N-type MOS transistors included in the N-type block **724** shown in FIG. 7 are for illustrative purposes. Using multiple intermediate control signals to control multiple inputs of the N-type block and/or the P-type block is possible. FIG. 8 is a diagram illustrating a second circuit implementation of the output cell **600** shown in FIG. 6 according to an exemplary embodiment of the present invention. The exemplary output cell **800** includes a controller **802** and an output buffer **804**. The P-type block **822** has multiple P-type MOS transistors **M11** and **M12**, and the N-type block **824** has multiple N-type MOS transistors **M21** and **M22**. As each of the P-type block **822** and N-type block **824** has more than one MOS transistor, the controller **802** is therefore configured to provide multiple intermediate control signals **CS11**, **CS12**, **CS21**, **CS22** to multiple inputs of the output driver **804**. In this embodiment,

the controller **802** includes a control block **812** and a coupling block **814**. The coupling block **814** has a capacitor **C** coupled between gates of the MOS transistors **M11** and **M22**, and a resistor **R** coupled between the preceding control block **812** and the following output driver **804**. Regarding the control block **812**, it includes a plurality of N-type MOS transistors **M31**, **M32**, **M33** and a plurality of P-type MOS transistors **M41**, **M42**, **M43**, where MOS transistors **M31** and **M41** are controlled by a digital control bit **CB1** to determine which one of the bias voltages  $V_{BIAS\_11}$  and  $V_{BIAS\_21}$  should be outputted to the following resistor **R**, MOS transistors **M32** and **M42** are controlled by a digital control bit **CB2** to determine which one of the bias voltages  $V_{BIAS\_12}$  and  $V_{BIAS\_22}$  should be outputted as the intermediate control signal **CS12**, and MOS transistors **M33** and **M43** are controlled by a digital control bit **CB3** to determine which one of the bias voltages  $V_{BIAS\_13}$  and  $V_{BIAS\_23}$  should be transmitted as the intermediate control signal **CS21**. Besides, the RF input  $RF_{IN}$  is directly transmitted as the intermediate control signal **CS22**. The same objective of avoiding the voltage swing problem is achieved as the output driver **804** is not an inductor-loaded class-D<sup>-1</sup>/class-E amplifier.

It should be noted that the coupling block **714/814**, including the resistor **R** and the capacitor **C**, may have impact on the intermediate control signal, thus affecting the transient waveform of the RF output  $RF_{OUT}$ . Please refer to FIG. 9, which is a diagram illustrating a time-domain waveform of a single bit operation of the output cell **700** shown in FIG. 7. The time-domain waveform has a negative exponential ramping up at the positive edge due to the RC circuit bootstrapping effect resulting from charging via the resistor **R** and the capacitor **C**, and has an abrupt shutdown at the negative edge due to the immediate shutdown of the MOS transistors **M1** and **M2**. If the positive edge can also show an abrupt ramping up, an ideal zero-order-hold (ZOH) DAC behavior can be obtained. The present invention therefore proposes a solution which achieves the objective of setting the output cell **700** to have the ZOH DAC behavior by using a digitally-controlled charging technique such as a ZOH charging control.

FIG. 10 is a diagram illustrating a third circuit implementation of the output cell **600** shown in FIG. 6 according to an exemplary embodiment of the present invention. The exemplary output cell **1000** has a controller **1002** and an output driver **1004**. The output driver **1004** operates under a supply voltage  $V_{DD}$  (e.g., 3.5V), and generates an RF output  $RF_{OUT}$  according to intermediate control signals **CS11**, **CS12**, **CS21**, **CS22**. The P-type block **1022** has cascoded P-type MOS transistors **M11** and **M12**, and the N-type block **1024** has cascoded N-type MOS transistors **M21** and **M22**. In this embodiment, the output cell **1000** realizes the transient waveform control by changing the circuitry and control sequence of the controller **1002**. Specifically, the output cell **1000** is abruptly turned on and off in response to one bit of the digital ACW signal. Regarding the controller **1002**, it includes a control block **1012** and a coupling block **1014**. The coupling block **1014** has a resistor **R** and a capacitor **C**, where the desired abrupt turning on is performed through resistive pre-charging of the capacitor **C**. Further details are described as below.

Regarding the control block **1012**, it includes a plurality of P-type MOS transistors **M31**, **M32** and a plurality of N-type MOS transistors **M41**, **M42**, where MOS transistors **M32** and **M42** are controlled by a digital control bit **CB** to determine which one of the bias voltages  $V_{BIAS\_12}$  (e.g., 3.6V) and  $V_{BIAS\_22}$  (e.g., 1.8V) should be outputted as the intermediate control signal **CS12**, and the MOS transistors **M31** and **M41** are controlled by an inverse version of the digital control bit

CB (e.g.,  $\overline{\text{CB}}$  generated by an inverter **1013**) to determine which one of the bias voltages  $V_{BIAS\_11}$  (e.g., 3V) and  $V_{BIAS\_21}$  (e.g., 2.4V) should be outputted to the following resistor R. Besides, the RF input  $\text{RF}_{IN}$  is directly provided as the intermediate control signal CS22, and the bias voltage  $V_{BIAS\_22}$  is directly provided as the intermediate control signal CS21. It should be noted that the high impedance 3V node (i.e., 3V supplied to source of the P-type MOS transistor M31) is necessary for clamping a DC voltage level from leakage discharging at the positive supply rail due to AC signal coupling.

The digital control bit CB controls the output driver **1004** to operate in either an ON state or an OFF state. When the digital control bit CB is logic high (i.e.,  $\text{CB}='1'$ ), the MOS transistors M31, M42, M11, M12, M21, M22 are enabled (i.e., switched on) and MOS transistors M41 and M32 are disabled (i.e., switched off), the output driver **1004** operates in the ON state. It should be noted that ON/OFF states of the MOS transistors M11, M12, M21, M22 may also be controlled by the RF input  $\text{RF}_{IN}$ . For example, when  $\text{RF}_{IN}=0$ , the MOS transistor M22 is off no matter what CB is. Please refer to FIG. 11, which is a diagram illustrating an equivalent circuit of the output driver **1004** operating in an ON state. Supposing the average value of the RF input  $\text{RF}_{IN}$  is 0.6V resulting from the DC level toggling between 0V and 1.2V, the voltage across the AC coupling capacitor C is 2.4V. When the digital control bit CB is logic low (i.e.,  $\text{CB}='0'$ ), the MOS transistors M41 and M32 are enabled (i.e., switched on) and the MOS transistors M31, M42, M11, M12, M21, M22 are disabled (i.e., switched off), the output driver **1004** operates in the OFF state. Please refer to FIG. 12, which is a diagram illustrating an equivalent circuit of the output driver **1004** operating in an OFF state. When the output driver **1004** enters the OFF state, the controller **1002** is operative to maintain the potential difference of the capacitor C. As the bottom terminal of the capacitor C would be pulled low to 0V due to the RF input  $\text{RF}_{IN}$  gated off by earlier stages, a pre-charging voltage potential 2.4V is developed at the top terminal of the capacitor C. As can be readily seen from FIG. 11 and FIG. 12, no matter whether the output driver **1004** is operating in the ON state or the OFF state, the voltage across the capacitor C is fixed at 2.4V. When the digital control bit CB has a transition from '0' to '1', the output driver **1004** would leave the OFF state and enters the ON state. As the bottom terminal of the capacitor C would be increased to the average value of the RF input  $\text{RF}_{IN}$  (e.g., 0.6V), the top terminal of the capacitor C would be correspondingly boosted to 3.0V (e.g., 2.4V+0.6V), which is identical to the desired DC bias level needed under the ON state. In this way, the RC boot-strapping effect resulting from charging via the resistor R and the capacitor C is avoided.

FIG. 13 is a diagram illustrating a time-domain waveform of a single bit operation of the output cell **1000** shown in FIG. 10. As a potential difference maintenance phase for the AC coupling capacitor C is added during the OFF state to eliminate the long transient settling resulting from the RC boot-strapping effect, the output cell **1000** is abruptly turned on and off in response to the digital control bit CB (i.e., one bit of the digital ACW signal). Hence, with a proper change of the controller circuitry as well as related control sequence, the output cell **1000** may have an ideal ZOH DAC behavior as shown in FIG. 13.

It should be noted that the proposed ZOH capacitor charging control technique is not limited to the DPA cell design shown in FIG. 10. For example, the proposed ZOH capacitor charging control technique may be applied to any of the

output cells **700** and **800** for transient waveform control. These alternative designs all fall within the scope of the present invention.

As shown in FIG. 9, the time-domain waveform has a negative exponential ramping up at the positive edge due to the RC boot-strapping effect, and has an abrupt shutdown at the negative edge due to the immediate shutdown of the MOS transistors M1 and M2. If the negative edge can also show a corresponding exponential ramping down, the one-bit pulse is roughly equivalently 1<sup>st</sup> order low-pass filtered at the baseband or bandpass filtered at the RF carrier. That is, reduction of the out-of-band (OOB) noise/replica may be achieved when the output cell is capable of generating a one-bit pulse having a negative exponential ramping up at the positive edge and a corresponding negative exponential ramping down at the negative edge. The present invention proposes a solution which achieves the objective by using a digitally-controlled charging technique such as an RC-interpolation charging control.

FIG. 14 is a diagram illustrating a fourth circuit implementation of the output cell **600** shown in FIG. 6 according to an exemplary embodiment of the present invention. The exemplary output cell **1400** has a controller **1402** and an output driver **1404**. The output driver **1404** operates under a supply voltage  $V_{DD}$  (e.g., 3.1V), and generates an RF output  $\text{RF}_{OUT}$  according to intermediate control signals CS11, CS12, CS21, CS22. The P-type block **1422** has cascoded P-type MOS transistors M11 and M12, and the N-type block **1424** has cascoded N-type MOS transistors M21 and M22. In this embodiment, the output cell **1400** realizes the RF bandpass filtering by changing the circuitry and control sequence of the controller **1402**. Specifically, the output cell **1400** is gradually turned on and off in response to one bit of the digital ACW signal (i.e., a digital control bit CB). Regarding the controller **1402**, it includes a control block **1412** and a coupling block **1414**. The coupling block **1414** has a resistor R and a capacitor C, where the desired gradual turning on and off is performed through resistive charging of the capacitor C. Further details are described as below.

Regarding the control block **1412**, it includes a control logic **1416**, a plurality of P-type MOS transistors M31, M32 and a plurality of N-type MOS transistors M41, M42. The control logic **1416** is arranged to generate a plurality of control outputs Ctrl and CB' according to a digital control bit CB (e.g., one bit of a digital ACW signal). Please refer to FIG. 15, which is a waveform diagram of the digital control bit CB and the control outputs CB' and Ctrl according to an exemplary embodiment of the present invention. In one exemplary design, the control output CB' may be derived from delaying the transition from a logic high level to a logic low level of the digital control bit CB. Hence, compared to the digital control bit CB, the control output CB' has extended logic-high periods. Regarding the control signal Ctrl, it may be derived from delaying an inverse version of the digital control bit CB. However, this is for illustrative purposes only, and is not meant to be a limitation of the present invention.

The MOS transistors M32 and M42 are controlled by the control output CB' to determine which one of the bias voltages  $V_{BIAS\_12}$  (e.g., 3.1V) and  $V_{BIAS\_22}$  (e.g., 1.55V) should be outputted as the intermediate control signal CS12. The MOS transistors M31 and M41 are controlled by the control output Ctrl to determine which one of the bias voltages  $V_{BIAS\_11}$  (e.g., 3.1V) and  $V_{BIAS\_21}$  (e.g., 2.5V) should be outputted to the following resistor R. Besides, the RF input  $\text{RF}_{IN}$  is directly transmitted as the intermediate control signal CS22, and the bias voltage  $V_{BIAS\_22}$  is directly transmitted as the intermediate control signal CS21.

The control outputs Ctrl and CB' control the output driver **1404** to operate in an ON state, a pre-charging stage or an OFF state. When the control output CB' is logic high (i.e., CB'='1') and the control output Ctrl is also logic high (i.e., Ctrl='1') during the period between  $T_2$  and  $T_3$ , the MOS transistors **M41**, **M42**, **M11**, **M12**, **M21**, **M22** are enabled (i.e., switched on) and MOS transistors **M31** and **M32** are disabled (i.e., switched off), the output driver **1404** operates in the ON state as shown in FIG. **16**, which is a diagram illustrating an equivalent circuit of the output driver **1404** operating in an ON state.

When the control output CB' is logic high (i.e., CB'='1') and the control output Ctrl is logic low (i.e., Ctrl='0'), the MOS transistors **M31**, **M42**, **M11**, **M12**, **M21**, **M22** are enabled (i.e., switched on) and the MOS transistors **M41**, **M32** are disabled (i.e., switched off) during the period between  $T_3$  and  $T_4$ , the output driver **1404** operates in the pre-charging state. Specifically, when a negative edge of the digital control bit CB is indicative of an ON-to-OFF state transition of the output driver **1404** at  $T_3$ , the control block **1412** is operative to delay the ON-to-OFF state transition and pre-charge the capacitor C concurrently. Please refer to FIG. **17**, which is a diagram illustrating an equivalent circuit of the output driver **1404** operating in a pre-charging state. When the output driver **1404** enters the pre-charging state, the controller **1402** is operative to pre-charge the capacitor C. It should be noted that the bottom terminal of the capacitor C is not pulled low to 0V right away, otherwise the abrupt shut-down causes no slow transient at the ON-to-OFF transition. The pre-charging voltage 3.1V is intentionally supplied to the capacitor C, thereby allowing the output driver **1404** to have an exponential RC behavior at the negative edge.

When the control output CB' is logic low (i.e., CB'='0') and the control output Ctrl is logic high (i.e., Ctrl='1'), the MOS transistors **M32**, **M41** are enabled (i.e., switched on) and the MOS transistors **M31**, **M42**, **M11**, **M12**, **M21**, **M22** are disabled (i.e., switched off) during the period between  $T_4$  and  $T_5$ , the output driver **1404** operates in the OFF state. Specifically, when the control output CB' has a transition from '1' to '0' and the control output Ctrl has a transition from '0' to '1', the output driver **1404** would leave the pre-charging state and enters the OFF state and the bottom terminal of the capacitor C would be pulled low to 0V as shown in FIG. **18**, which is a diagram illustrating an equivalent circuit of the output driver **1404** operating in an OFF state.

FIG. **19** is a diagram illustrating a time-domain waveform of a single bit operation of the output cell **1400** shown in FIG. **14**. As the shutdown operation is delayed due to a pre-charging state inserted between the ON state and the OFF state, the negative exponential RC ramping down is allowed to occur at the negative edge. In this way, the output cell **1400** is gradually turned on and off in response to the digital control bit CB (i.e., one bit of the digital ACW signal). Hence, with a proper change of the controller circuitry as well as control sequence, the output cell **1400** having bandpass filtering is realized. The output cell **1400** may achieve maximum available efficiency of the battery and reduces the OOB noise floor for multi-radio coexistence.

It should be noted that the proposed RC-interpolation charging control technique is not limited to the DPA cell design shown in FIG. **14**. For example, the proposed RC-interpolation charging control technique may be applied to any of the output cells **700** and **800** for transient waveform control. These alternative designs all fall within the scope of the present invention.

The exemplary DPA output stage cell mentioned above may be employed for implementing the output stage **208** in

the proposed multi-stage DPA **200/300**. However, this is not meant to be a limitation of the present invention. Any DPA design using the exemplary DPA output stage cell mentioned above falls within the scope of the present invention.

Furthermore, the exemplary DPA output stage cell mentioned above may be used in a DPA coupled to a jointed transmission/reception (T/R) RF port. For example, the output signal RF\_OUT shown in FIG. **2**/FIG. **3** is directly coupled to a balun. In the transmitting mode, the limited voltage rail-to-rail swing ensures that transmitter device and receiver devices are ensured to be reliable for all allowable battery voltage levels. Hence, the proposed battery-efficient design can be realized without any constraint on circuit reliability. In the receiving mode, the DPA is turned off through gates of cascoded MOS transistors in each output cell. High balun Z-transformation ratio increases the matching gain of the low-noise amplifier (LNA), resulting in high voltage gain, low noise figure (NF), and low power consumption. To put it simply, the proposed DPA design has several advantages/benefits, such as limited voltage rail-to-rail swing and higher load-line impedance. The limited voltage rail-to-rail swing ensures the reliability of core devices and I/O devices. The higher load-line impedance allows smaller transistor sizes, which reduces driven load. Thus, the current consumption of the driver stage may be highly reduced while maintaining the phase noise requirements.

Due to the feedback path established by magnetic coupling and/or direct coupling (e.g., coupling via the printed circuit board (PCB) ground and/or the package ground), the transmitter output may be fed back to a clock source in the transmitter, which may degrade the transmitter performance. Thus, there is a need for a pulling mitigation mechanism employed to improve the transmitter performance. FIG. **20** is a diagram illustrating a transmitter employing an exemplary pulling mitigation mechanism according to an embodiment of the present invention. The transmitter **2000** includes a clock source **2002**, a power amplifier (PA) **2004**, and a direct current (DC) voltage tuning circuit **2006**. The PA **2004** is arranged for receiving a radio-frequency (RF) clock RF\_IN derived from the clock source **2002**, and producing an output signal RF\_OUT according to at least the RF clock RF\_IN. By way of example, but not limitation, the clock source **2002** may include a local oscillator (LO) such as a digitally controlled oscillator (DCO). The DC voltage tuning circuit **2006** is arranged for tuning at least one DC voltage  $V_{DC}$  supplied to the PA **2004** for pulling mitigation of the clock source **2002**. Specifically, the phase of the output signal RF\_OUT is adjusted in response to the at least one DC voltage  $V_{DC}$  tuned by the DC voltage tuning circuit **2006**. In this way, the undesired pulling of the clock source **2002** can be mitigated by applying phase tuning upon the feedback loop from the transmitter output (i.e., the output signal RF\_OUT of the PA **2004**) to the clock source **2002**. By way of example, but not limitation, the at least one DC voltage  $V_{DC}$  may include a supply voltage or a bias voltage.

The proposed pulling mitigation mechanism may be applied to the above-mentioned multi-stage DPA. In one exemplary design, the PA **2004** shown in FIG. **20** includes a DPA such as the exemplary multi-stage DPA **100/200/300**, and the at least one DC voltage  $V_{DC}$  includes supply voltage(s) of the driver stage **106/206/306** and/or the output stage **108/208**. FIG. **21** is a diagram illustrating a multi-stage DPA with supply voltages tuned by a DC voltage tuning circuit for pulling mitigation of a clock source (e.g., a DCO). As shown in FIG. **21**, the aforementioned multi-stage DPA **200/300** is modified to have supply voltage(s) tuned by the DC voltage tuning circuit **2006**, where a first driver-stage

13

supply voltage  $V_{DD,driver\_1}$  is supplied to drivers in the first cascaded stage **212/312** of the driver stage **206/306**, a second driver-stage supply voltage  $V_{DD,driver\_2}$  is supplied to drivers in the second cascaded stage **214** of the driver stage **206/306**, a third driver-stage supply voltage  $V_{DD,driver\_3}$  is supplied to drivers in the third cascaded stage **216** of the driver stage **206/306**, and an output-stage supply voltage  $V_{DD,output}$  is supplied to output cells in the output stage **208**. It should be noted that driver-stage supply voltages  $V_{DD,driver\_1}$ - $V_{DD,driver\_3}$  and output-stage supply voltage  $V_{DD,output}$  may have the same DC voltage level or different DC voltage levels.

In this example, all of the cells in the multi-stage DPA **200/300** are reused for feedback phase control via propagational delay adjustment. However, this is for illustrative purposes only, and is not meant to be a limitation of the present invention. In other words, the same objective of controlling the phase of the output signal RF\_OUT for clock source pulling mitigation may be achieved by tuning supply voltage of at least one of the stages **212/312**, **214**, **216**, and **208**.

As mentioned above, the phase of the output signal RF\_OUT dominates the pulling mitigation performance. With a proper setting of the at least one DC voltage  $V_{DC}$  supplied to the PA **2004**, the pulling mitigation of the clock source **2002** may be optimized by optimally setting the aggressing phase generated by the PA versus the victim phase. The present invention therefore proposes adding a calibration element to the proposed pulling mitigation mechanism. Alternative designs of the transmitter **2000** shown in FIG. **20** are described as below.

FIG. **22** is a diagram illustrating a transmitter employing another exemplary pulling mitigation mechanism according to an embodiment of the present invention. The transmitter **2200** includes a detector **2202** and the aforementioned clock source **2002**, PA **2004** and DC voltage tuning circuit **2006**. The detector **2202** is operable of producing a statistic STAT of a delay (or the phase) between the RF clock  $RF_{IN}$  and the output signal RF\_OUT. The DC voltage tuning circuit **2006** refers to the statistic STAT to adjust the at least one DC voltage  $V_{DC}$ .

FIG. **23** is a diagram illustrating a transmitter employing yet another exemplary pulling mitigation mechanism according to an embodiment of the present invention. The transmitter **2300** includes a time-to-digital converter (TDC) **2302** and the aforementioned clock source **2002**, PA **2004** and DC voltage tuning circuit **2006**. For example, the transmitter **2300** is an ADPLL-based transmitter, and the TDC **2302** is reused in the feedback phase control. The DC voltage  $V_{DC}$  supplied to the PA **2004** is also shared with the TDC **2302**. The timing delay characteristics of the TDC **2302** and the PA **2004** are highly correlated hence the TDC could be used as a 'proxy' for the PA delay. The TDC **2302** is arranged to digitally output the quantized time difference between the generated RF\_IN clock and a reference clock (not shown). Thus generated TDC output TDC\_OUT can be used to estimate the inverter delay. The DC voltage tuning circuit **2006** is arranged to operate in response to calculating of the TDC output TDC\_OUT, where the calculating of the TDC output TDC\_OUT is operable to provide an estimate of the TDC element delay characteristic (e.g., an inverter delay). Hence, based on the estimate of the TDC element delay characteristic, the DC voltage tuning circuit **2006** is arranged to adjust the DC voltage  $V_{DC}$  for substantially maintaining the TDC element delay characteristic.

Those skilled in the art will readily observe that numerous modifications and alterations of the device and method may be made while retaining the teachings of the invention.

14

Accordingly, the above disclosure should be construed as limited only by the metes and bounds of the appended claims.

What is claimed is:

1. A digitally-controlled power amplifier (DPA) with band-pass filtering, comprising:
  - a radio-frequency (RF) clock input, arranged for receiving an RF clock;
  - an amplitude control word (ACW) input, arranged for receiving a digital ACW signal; and
  - a plurality of DPA cells, coupled to said RF clock and said digital ACW signal, wherein at least one of said DPA cells is gradually turned on and off in response to at least one bit of said digital ACW signal.
2. The DPA of claim 1, wherein gradual turning on and off is performed through resistive charging of a capacitor.
3. The DPA of claim 1, wherein said at least one of said DPA cells comprises:
  - a controller, arranged for receiving at least a bit of said digital ACW signal, and generating a plurality of intermediate control signals; and
  - an output driver, arranged for generating an RF output according to said intermediate control signals, said output driver comprising:
    - a P-type block, having at least a P-type MOS transistor responsive to a first intermediate control signal of said intermediate control signals; and
    - an N-type block, having at least an N-type MOS transistor responsive to a second intermediate control signal of said intermediate control signals.
4. The DPA of claim 3, wherein said controller comprises:
  - a coupling block, comprising a capacitor having a first end coupled to a gate of said P-type MOS transistor and a second end coupled to a gate of said N-type MOS transistor; and
  - a control block, arranged for controlling said intermediate control signals according to at least said bit of said digital ACW signal.
5. The DPA of claim 4, wherein said coupling block further comprises a resistor having a first end coupled to said control block and a second end coupled to said first end of said capacitor.
6. The DPA of claim 4, wherein when said bit of said digital ACW signal is indicative of an ON-to-OFF state transition of said output driver, said control block is operative to delay said ON-to-OFF state transition and pre-charge said capacitor concurrently.
7. The DPA of claim 3, wherein said output driver is a class-D amplifier.
8. A digitally-controlled power amplifier (DPA) with transient waveform control, comprising:
  - a radio-frequency (RF) clock input, arranged for receiving an RF clock;
  - an amplitude control word (ACW) input, arranged for receiving a digital ACW signal; and
  - a plurality of DPA cells, coupled to said RF clock and said digital ACW signal, wherein at least one of said DPA cells is abruptly turned on and off in response to at least one bit of said digital ACW signal.
9. The DPA of claim 8, wherein abrupt turning on is performed through resistive charging of a capacitor.
10. The DPA of claim 8, wherein said at least one of said DPA cells comprises:
  - a controller, arranged for receiving at least a bit of said digital ACW signal, and generating a plurality of intermediate control signals; and

## 15

an output driver, arranged for generating an RF output according to said intermediate control signals, said output driver comprising:

a P-type block, having at least a P-type MOS transistor responsive to a first intermediate control signal of said intermediate control signals; and

an N-type block, having at least an N-type MOS transistor responsive to a second intermediate control signal of said intermediate control signals.

11. The DPA of claim 10, wherein said controller comprises:

a coupling block, comprising a capacitor having a first end coupled to a gate of said P-type MOS transistor and a second end coupled to a gate of said N-type MOS transistor; and

a control block, arranged for controlling said intermediate control signals according to at least said bit of said digital ACW signal.

12. The DPA of claim 11, wherein said coupling block further comprises a resistor having a first end coupled to said control block and a second end coupled to said first end of said capacitor.

13. The DPA of claim 11, wherein when said output driver enters an OFF state, said control block is operative to maintain a potential difference of said capacitor.

14. The DPA of claim 10, wherein said output driver is a class-D amplifier.

15. A digitally-controlled power amplifier (DPA) cell, comprising:

a controller, arranged for generating a plurality of intermediate control signals according to a plurality of bias voltages, a radio-frequency (RF) input, and a bit of a digital amplitude control word (ACW) signal; and

an output driver, arranged for generating an RF output according to said intermediate control signals, said output driver comprising:

a P-type block, having at least a P-type MOS transistor responsive to a first intermediate control signal of said intermediate control signals; and

an N-type block, having at least an N-type MOS transistor responsive to a second intermediate control signal of said intermediate control signals;

wherein said controller refers to said bit of said ACW signal to select at least one of said bias voltages to set at least one of said intermediate control signals.

## 16

16. The DPA cell of claim 15, wherein said controller comprises:

a coupling block, comprising a capacitor having a first end coupled to a gate of said P-type MOS transistor and a second end coupled to a gate of said N-type MOS transistor; and

a control block, arranged for controlling said intermediate control signals according to said bias voltages, said RF input, and said bit of said digital ACW signal.

17. The DPA cell of claim 16, wherein when said bit of said digital ACW signal is indicative of an ON-to-OFF state transition of said output driver, said control block is operative to delay said ON-to-OFF state transition and pre-charge said capacitor concurrently.

18. The DPA cell of claim 16, wherein when said output driver enters an OFF state, said control block is operative to maintain a potential difference of said capacitor.

19. The DPA cell of claim 15, wherein said output driver is a class-D amplifier.

20. A digitally-controlled power amplifier (DPA) cell, comprising:

a controller, arranged for generating a plurality of intermediate control signals according to a plurality of bias voltages, a radio-frequency (RF) input, and a bit of a digital amplitude control word (ACW) signal; and

an output driver, arranged for generating an RF output according to said intermediate control signals, said output driver comprising:

a P-type block, having at least a P-type MOS transistor responsive to a first intermediate control signal of said intermediate control signals; and

an N-type block, having at least an N-type MOS transistor responsive to a second intermediate control signal of said intermediate control signals;

wherein said controller comprises:

a control block, arranged for controlling said intermediate control signals according to said bias voltages, said RF input, and said bit of said digital ACW signal; and

a coupling block, comprising:

a capacitor having a first end coupled to a gate of said P-type MOS transistor and a second end coupled to a gate of said N-type MOS transistor; and

a resistor having a first end coupled to said control block and a second end coupled to said first end of said capacitor.

\* \* \* \* \*