

(12) **United States Patent**
Ximenes et al.

(10) **Patent No.:** **US 9,401,677 B2**
(45) **Date of Patent:** **Jul. 26, 2016**

(54) **SPLIT TRANSFORMER BASED DIGITALLY CONTROLLED OSCILLATOR AND DC-COUPLED BUFFER CIRCUIT THEREFOR**

H03M 1/002 (2013.01); *H03M 1/201* (2013.01); *H03J 2200/10* (2013.01); *H03L 2207/50* (2013.01)

(71) Applicants: **Augusto Ronchini Ximenes**, Den Haag (NL); **Robert Bogdan Staszewski**, Dublin (IE)

(58) **Field of Classification Search**
CPC H03K 3/015; H03B 5/1265; H03B 5/1296; H03B 5/1228
USPC 330/10, 251, 297
See application file for complete search history.

(72) Inventors: **Augusto Ronchini Ximenes**, Den Haag (NL); **Robert Bogdan Staszewski**, Dublin (IE)

(56) **References Cited**

(73) Assignee: **Short Circuit Technologies LLC**, Rochester, NY (US)

U.S. PATENT DOCUMENTS

(*) Notice: Subject to any disclaimer, the term of this patent is extended or adjusted under 35 U.S.C. 154(b) by 0 days.

6,157,252 A * 12/2000 Compton H01L 29/94
257/E29.345
2010/0283061 A1* 11/2010 Kelley H03K 17/145
257/77

(21) Appl. No.: **14/831,119**

OTHER PUBLICATIONS

(22) Filed: **Aug. 20, 2015**

Andreani, P. et al., "A TX VCO for WCDMA/EDGE in 90 nm RF CMOS", IEEE J. Solid-State Circ., vol. 46, No. 7, pp. 1618-1626, Jul. 2011.

(65) **Prior Publication Data**
US 2016/0056799 A1 Feb. 25, 2016

(Continued)

Related U.S. Application Data

(60) Provisional application No. 62/039,481, filed on Aug. 20, 2014.

Primary Examiner — Jeffrey Shin
(74) *Attorney, Agent, or Firm* — Zaretsky Patent Group PC; Howard Zaretsky

(51) **Int. Cl.**
H03B 5/12 (2006.01)
H03B 1/00 (2006.01)
(Continued)

(57) **ABSTRACT**

(52) **U.S. Cl.**
CPC *H03B 5/1265* (2013.01); *G04F 10/005* (2013.01); *H03B 1/00* (2013.01); *H03B 5/1215* (2013.01); *H03B 5/1228* (2013.01); *H03B 5/1296* (2013.01); *H03K 3/015* (2013.01); *H03K 3/0315* (2013.01); *H03L 7/0802* (2013.01); *H03L 7/0893* (2013.01); *H03L 7/093* (2013.01); *H03L 7/1976* (2013.01);

A novel and useful LC-tank digitally controlled oscillator (DCO) incorporating a split transformer configuration. The LC-tank oscillator exhibits a significant reduction in area such that it is comparable in size to conventional ring oscillators (ROs) while still retaining its salient features of excellent phase noise and low sensitivity to supply variations. The oscillator incorporates an ultra-compact split transformer topology that is less susceptible to common-mode electromagnetic interference than regular high-Q LC tanks which is highly desirable in SoC environments. The oscillator, together with a novel dc-coupled buffer, can be incorporated within a wide range of circuit applications, including clock generators and an all-digital phase-locked loop (ADPLL) intended for wireline applications.

20 Claims, 11 Drawing Sheets

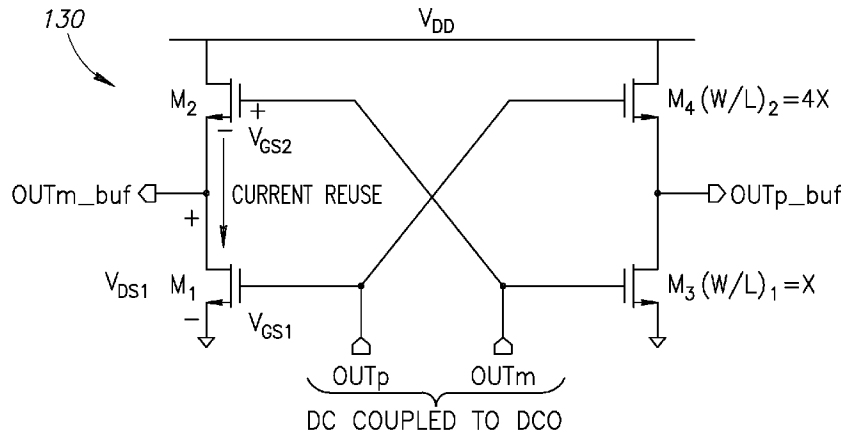

- (51) **Int. Cl.**
H03K 3/015 (2006.01)
G04F 10/00 (2006.01)
H03L 7/08 (2006.01)
H03M 1/00 (2006.01)
H03L 7/093 (2006.01)
H03M 1/20 (2006.01)
H03L 7/089 (2006.01)
H03L 7/197 (2006.01)
H03K 3/03 (2006.01)

(56) **References Cited**

OTHER PUBLICATIONS

- Babaie, M. et al., "A Class-F CMOS Oscillator", IEEE J. Solid-State Circ., vol. 48, No. 12, pp. 3120-3133, Dec. 2013.
 Borremans, J. et al., "A Single-Inductor Dual-Band VCO in a 0.06mm² 5.6GHz Multi-Band Front-End in 90nm Digital CMOS", ISSCC 2008, pp. 324-325, Feb. 2008.
 Fanori, L. et al., "A 2.4-to-5.3GHz Dual-Core CMOS VCO with Concentric 8-Shaped Coils", ISSCC 2014, pp. 370-371, Feb. 2014.
 Ham, D. et al., "Concepts and Methods in Optimization of Integrated LC VCOs", IEEE J. Solid-State Circ., vol. 36, No. 6, pp. 896-909, Jun. 2001.
 Hwang, I. C. et al., "A CMOS Self-Regulating VCO With Low Supply Sensitivity", IEEE J. Solid-State Circ., vol. 39, No. 1, pp. 42-48, Jan. 2004.
 Levantino, S. et al., "Frequency dependence on bias current in 5 GHz CMOS VCOs: impact on tuning range and flicker noise upconversion", JSSC, vol. 37, No. 8, pp. 1003-1011, Aug. 2002.

- Li, G. et al., "A Low-Phase-Noise Wide-Tuning-Range Oscillator Based on Resonant Mode Switching", IEEE J. Solid-State Circ., vol. 47, No. 6, pp. 1295-1308, Jun. 2012.
 Mazzanti, A. et al., "Class-C Harmonic CMOS VCOs, With a General Result on Phase Noise", IEEE J. Solid-State Circ., vol. 43, No. 12, pp. 2716-2729, Dec. 2008.
 Safarian, Z. et al., "A 1.3-6 GHz Triple-Mode CMOS VCO Using Coupled Inductors", IEEE 2008 Custom Integ. Circ. Conf. (CICC), pp. 69-72, 2008.
 Yim, S. M. et al., "Switched Resonators and Their Applications in a Dual-Band Monolithic CMOS-Tuned VCO", IEEE Trans. Microwave Theory, vol. 54, No. 1, pp. 74-81, Jan. 2006.
 Soltanian, B. et al., "An Ultra-Compact Differentially Tuned 6-GHz CMOS LC-VCO With Dynamic Common Mode Feedback", IEEE J. Solid-State Circ., vol. 42, No. 8, pp. 1635-1641, Aug. 2007.
 Tanabe, A. et al., "A Low-Power, Small Area Quadrature LC-VCO using miniature 3D Solenoid shaped Inductor", RFIC 2009, pp. 263-266, 2009.
 Tanabe, A. et al., "A Novel Variable Inductor Using a Bridge Circuit and Its Application to a 5-20 GHz Tunable LC-VCO", IEEE J. Solid-State Circ., vol. 46, No. 4, pp. 883-893, Apr. 2011.
 Babaie, M. et al., "A 0.06 mm² 11 mW Local Oscillator for the GSM Standard in 65 nm CMOS", IEEE J. Solid-State Circ., vol. 45, No. 7, pp. 1295-1304, Jul. 2010.
 Zheng, S. et al., "A 4.1-to-6.5GHz Transformer-Coupled CMOS Quadrature Digitally-Controlled Oscillator with Quantization Noise Suppression", RFIC 2012, pp. 519-522, Jun. 2012.

* cited by examiner

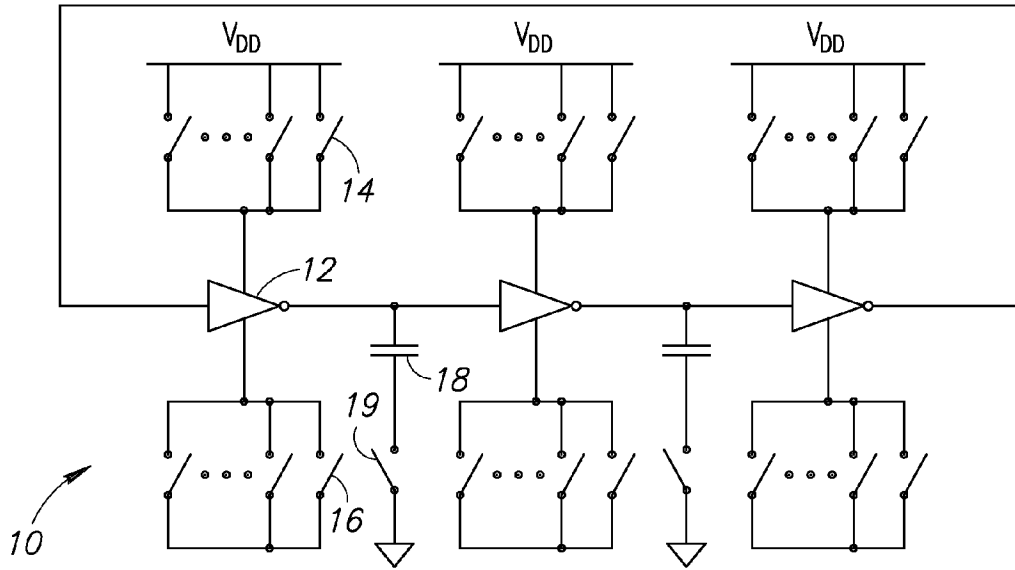

FIG. 1

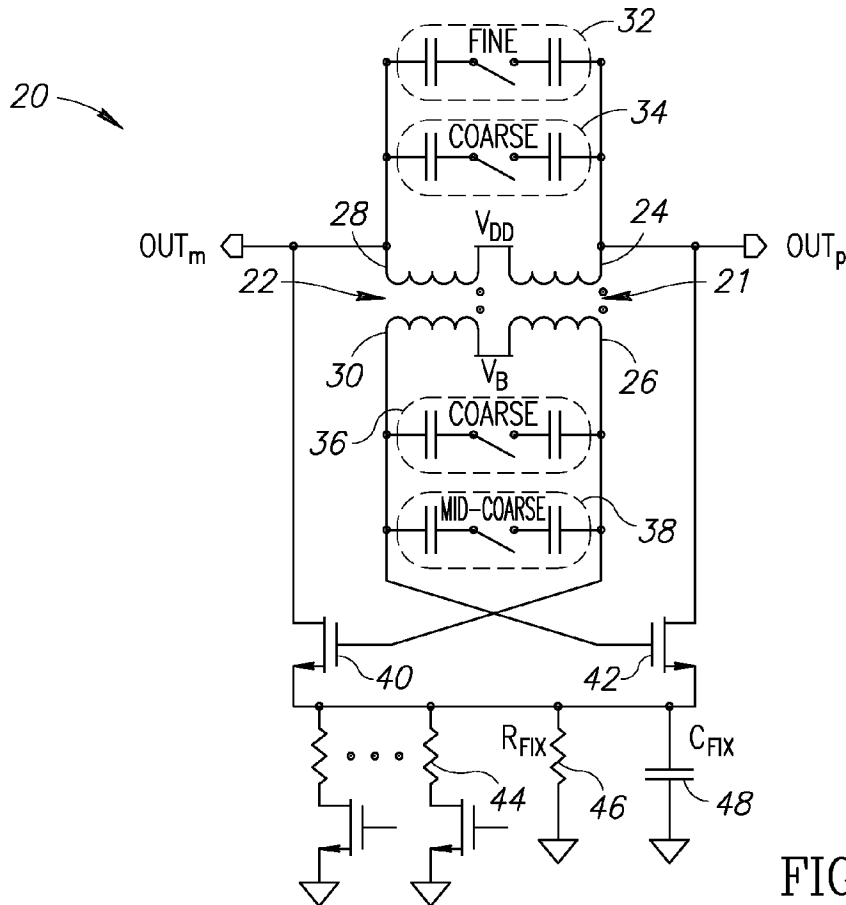

FIG. 2A

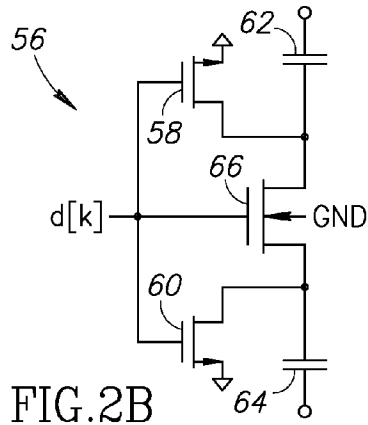

FIG. 2B

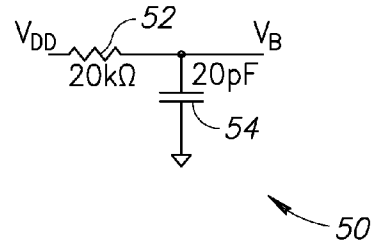

FIG. 2C

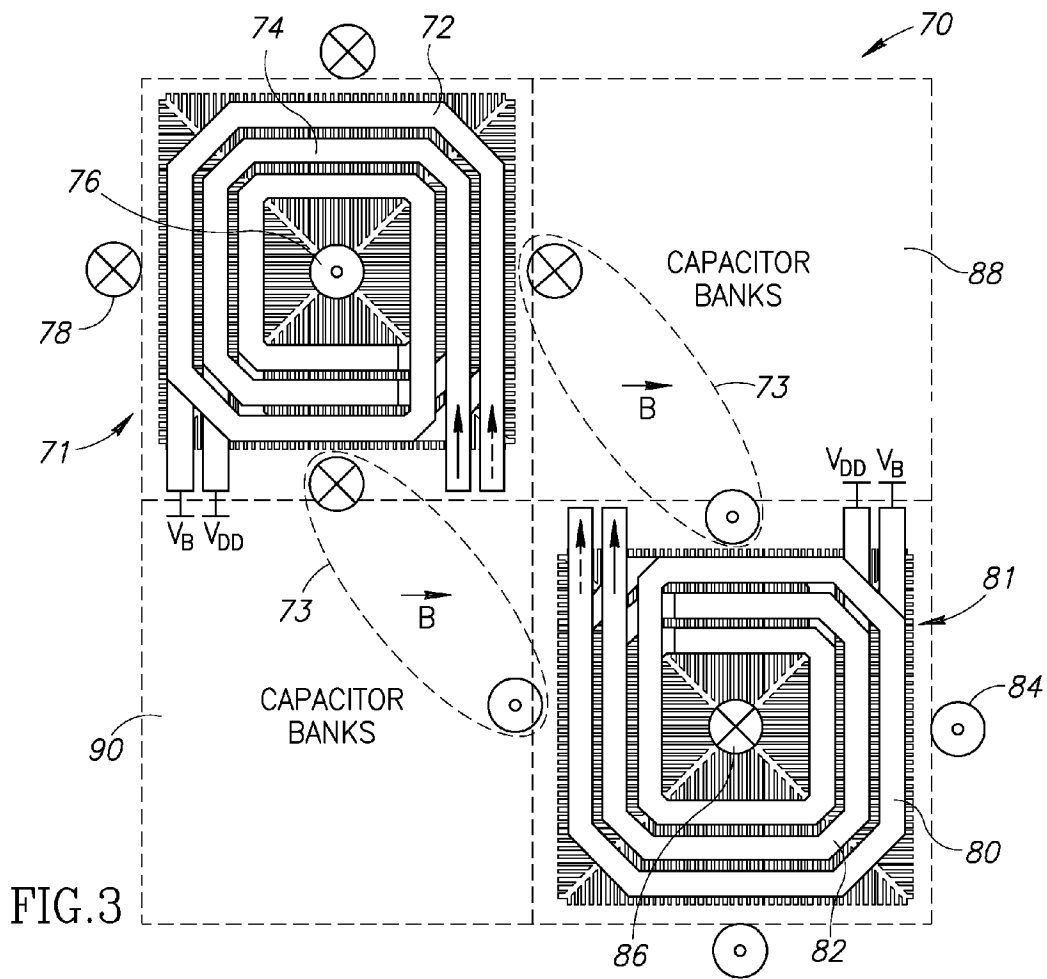

FIG. 3

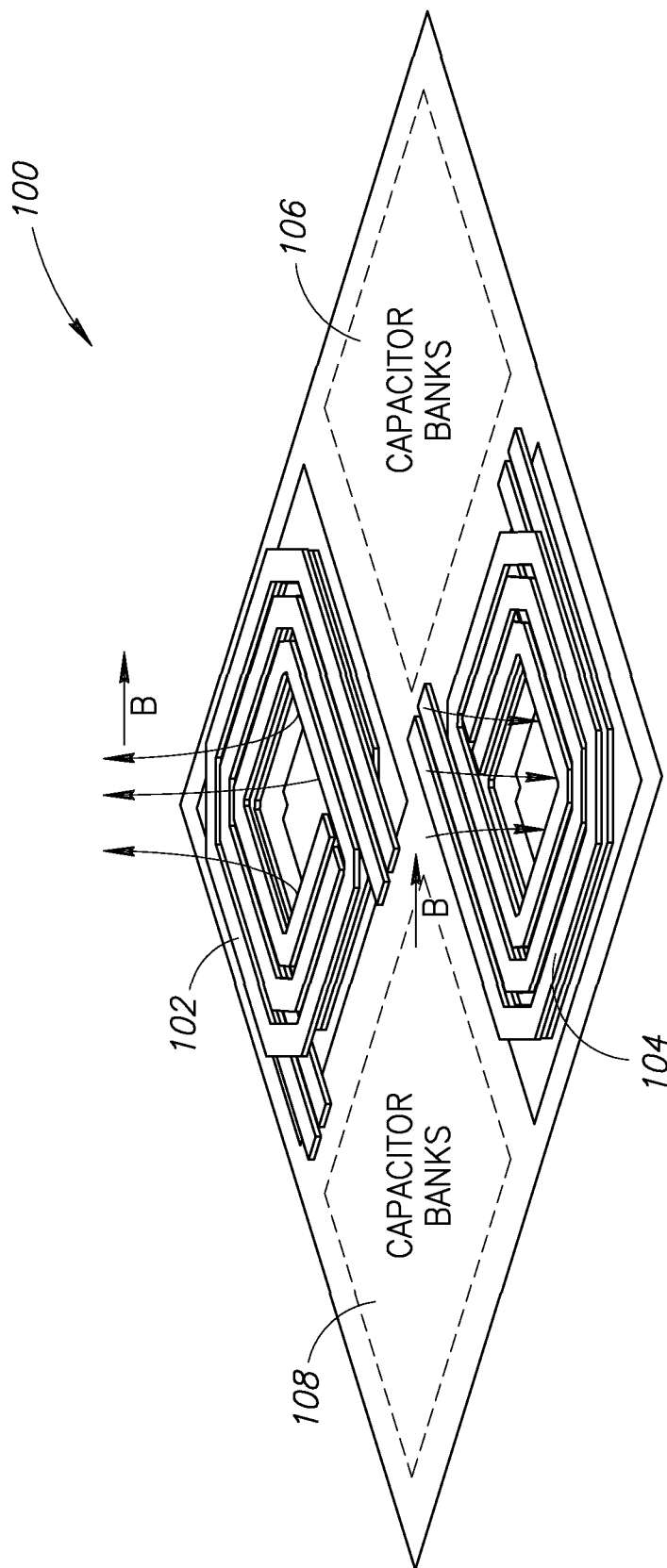

FIG. 4

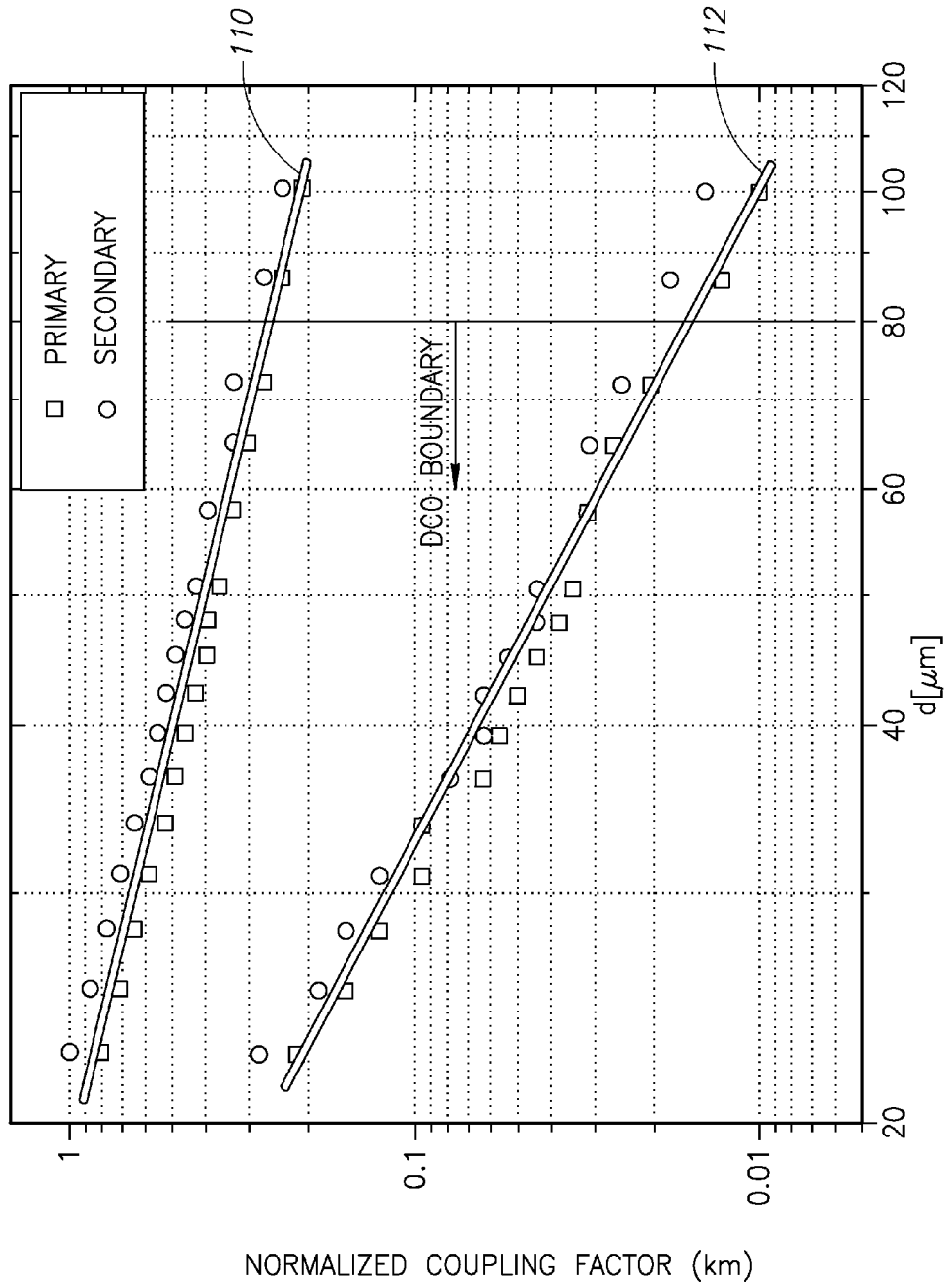

FIG.5

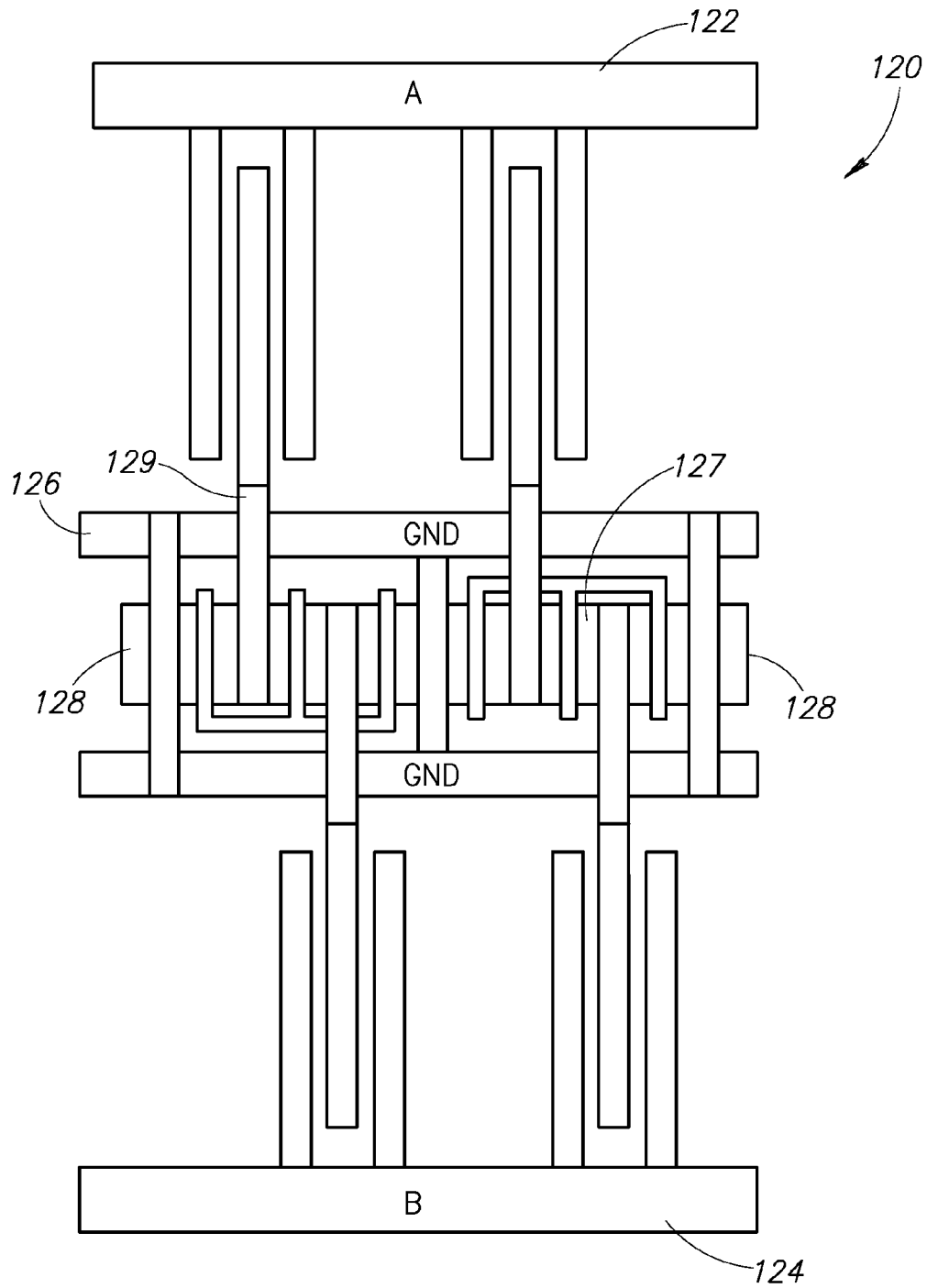

FIG.6

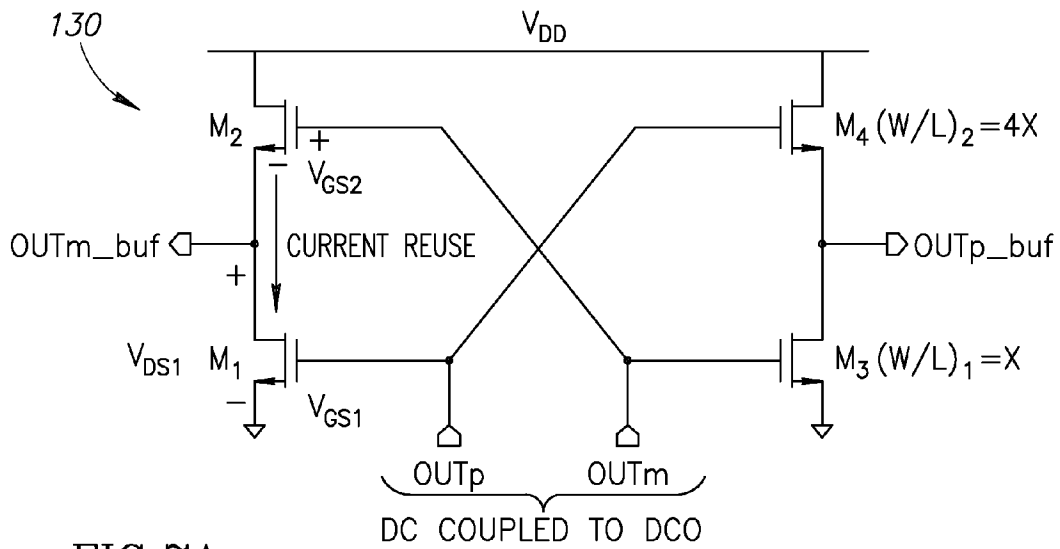

FIG. 7A

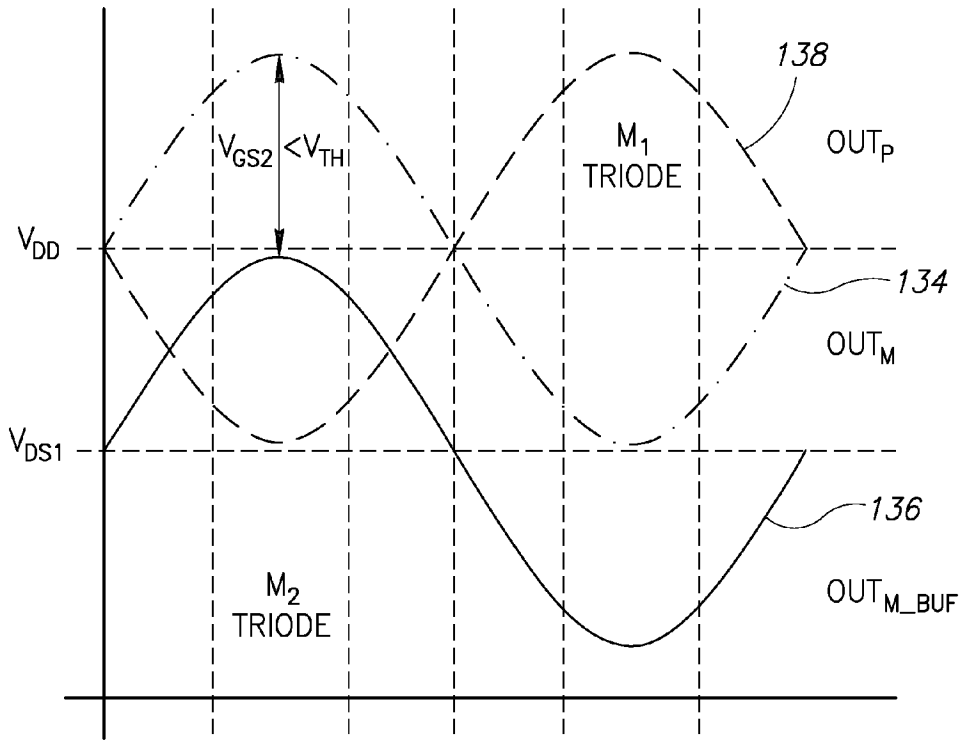

FIG. 7B

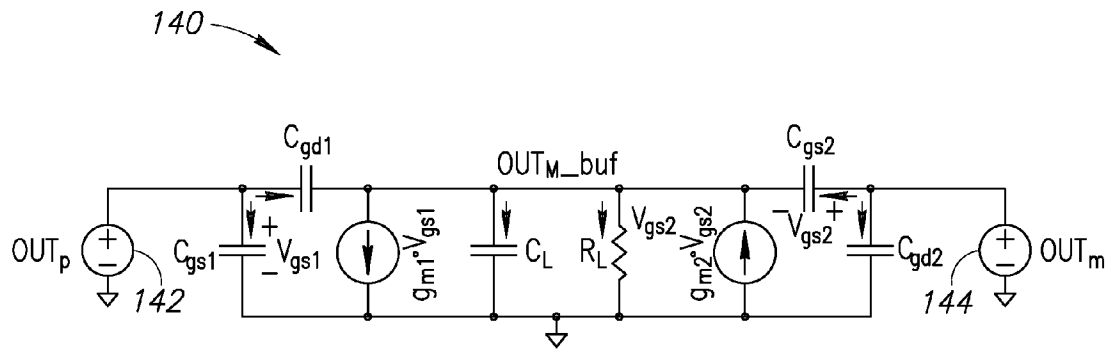

FIG. 7C

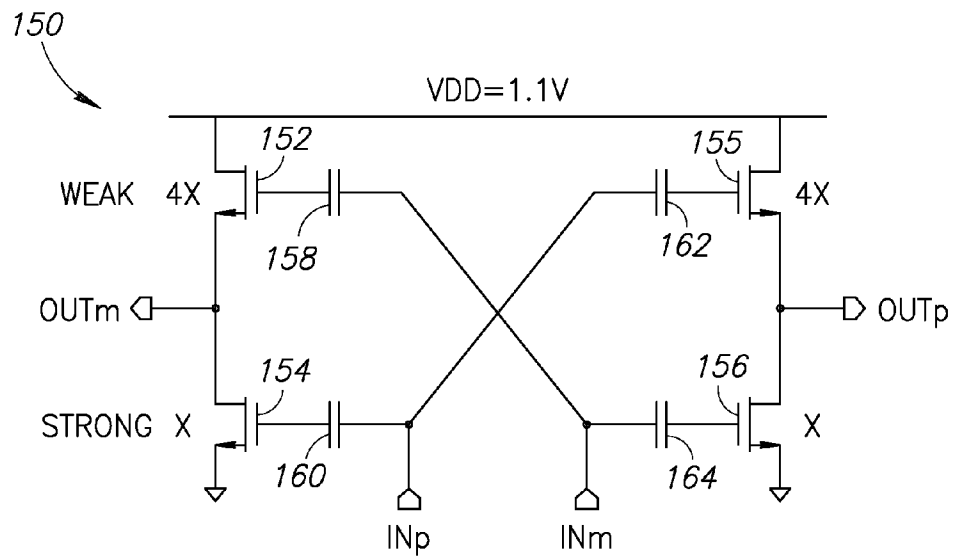

FIG. 8

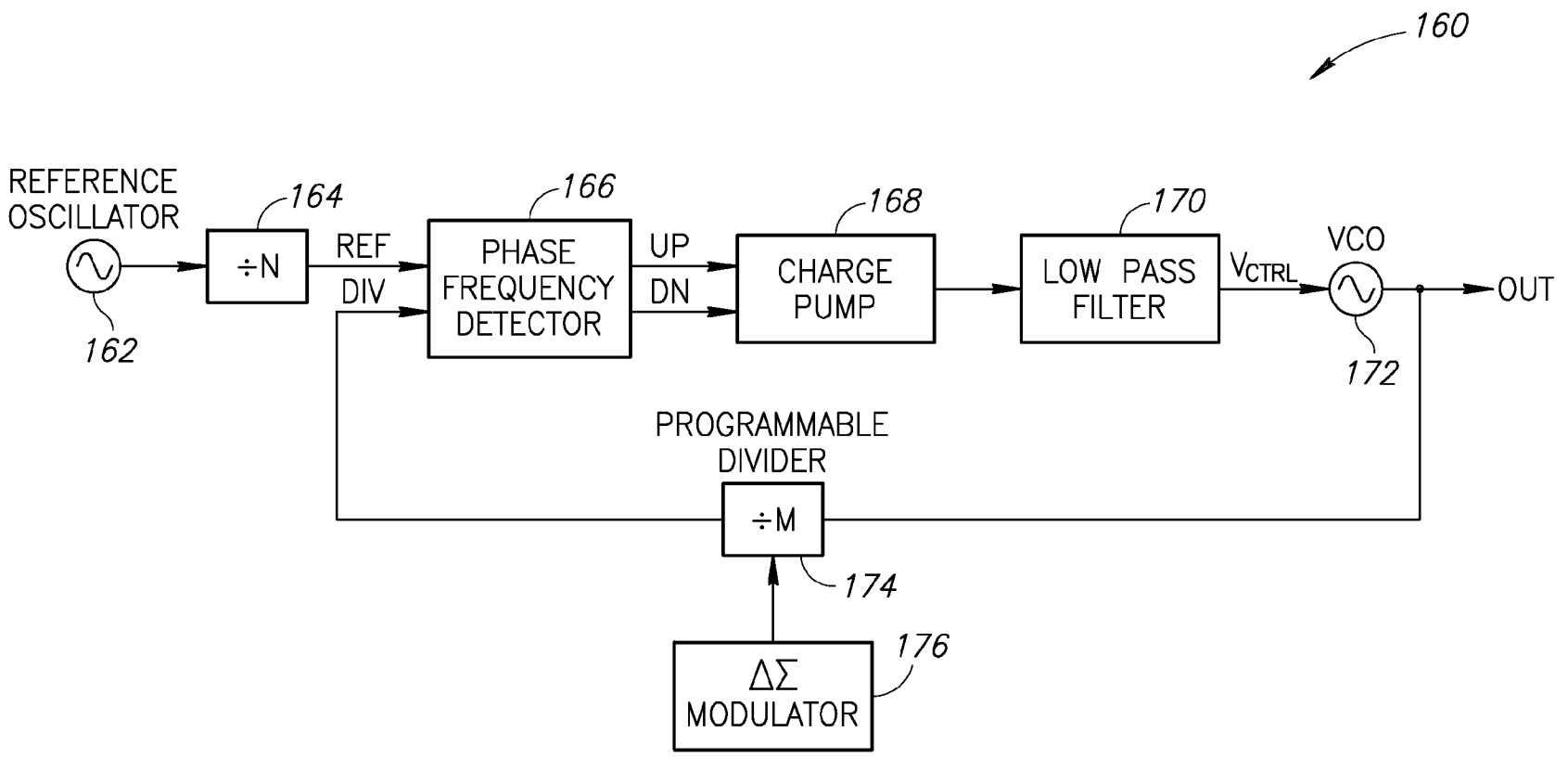

FIG. 9

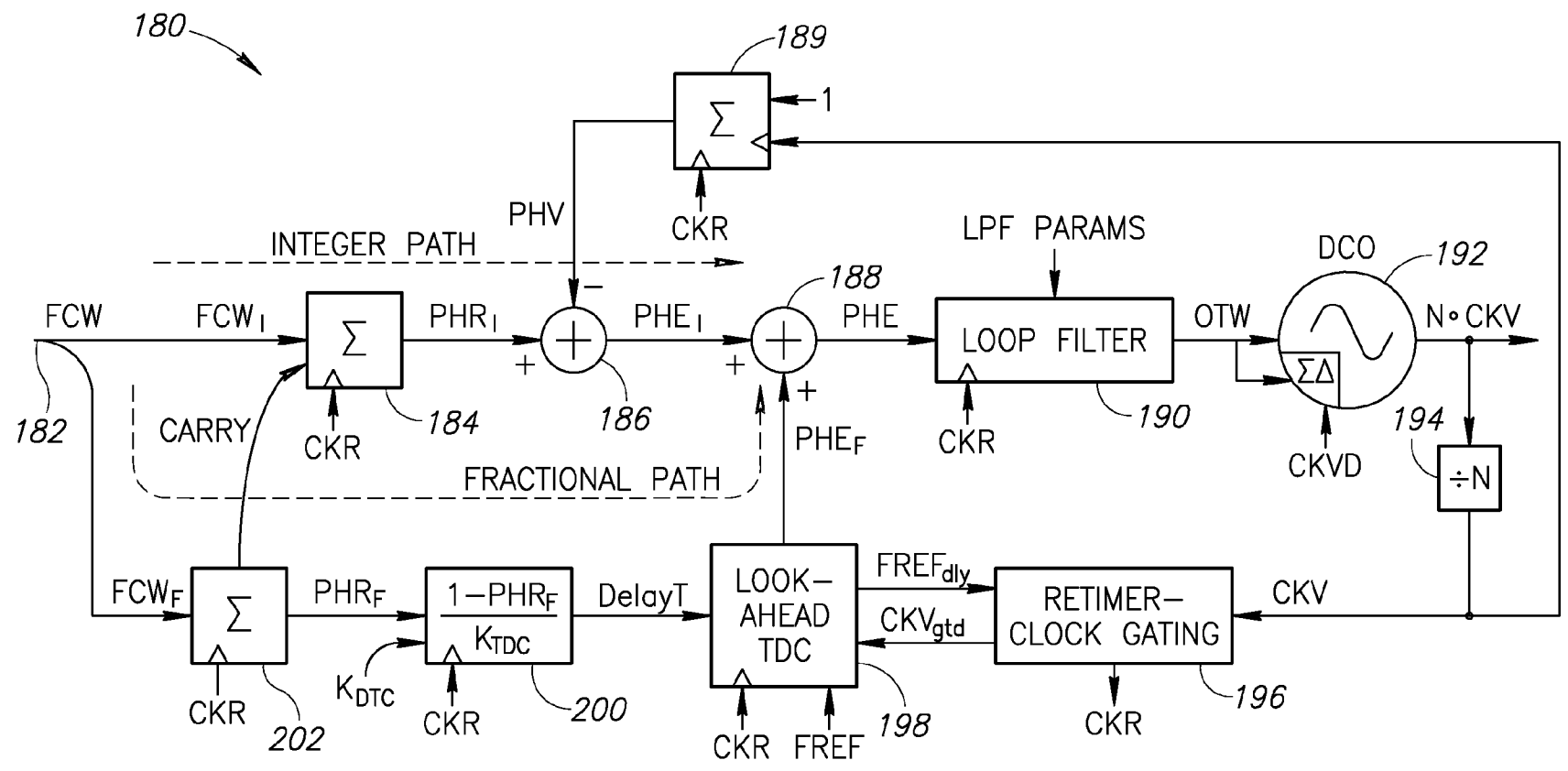

FIG.10

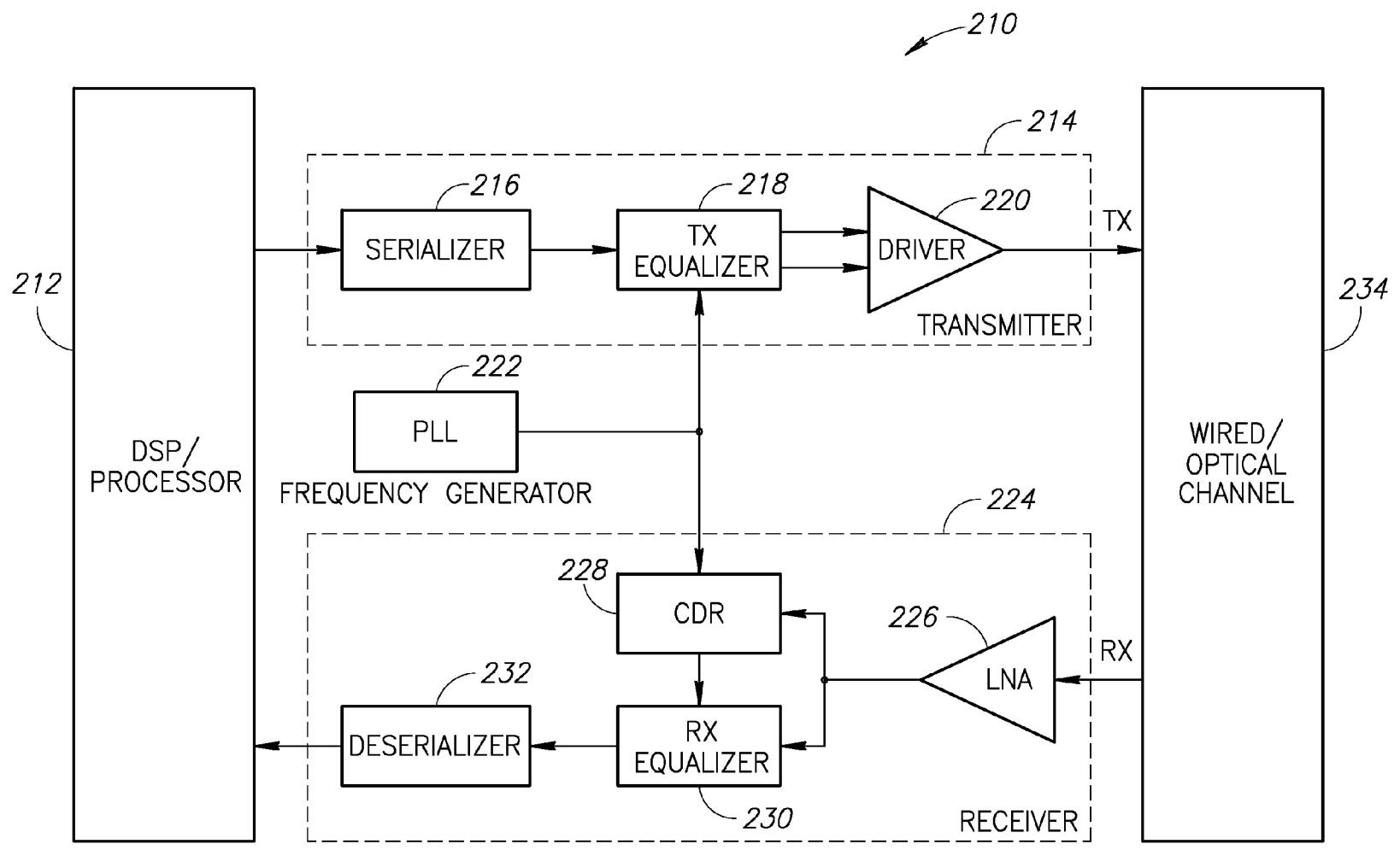

FIG.11

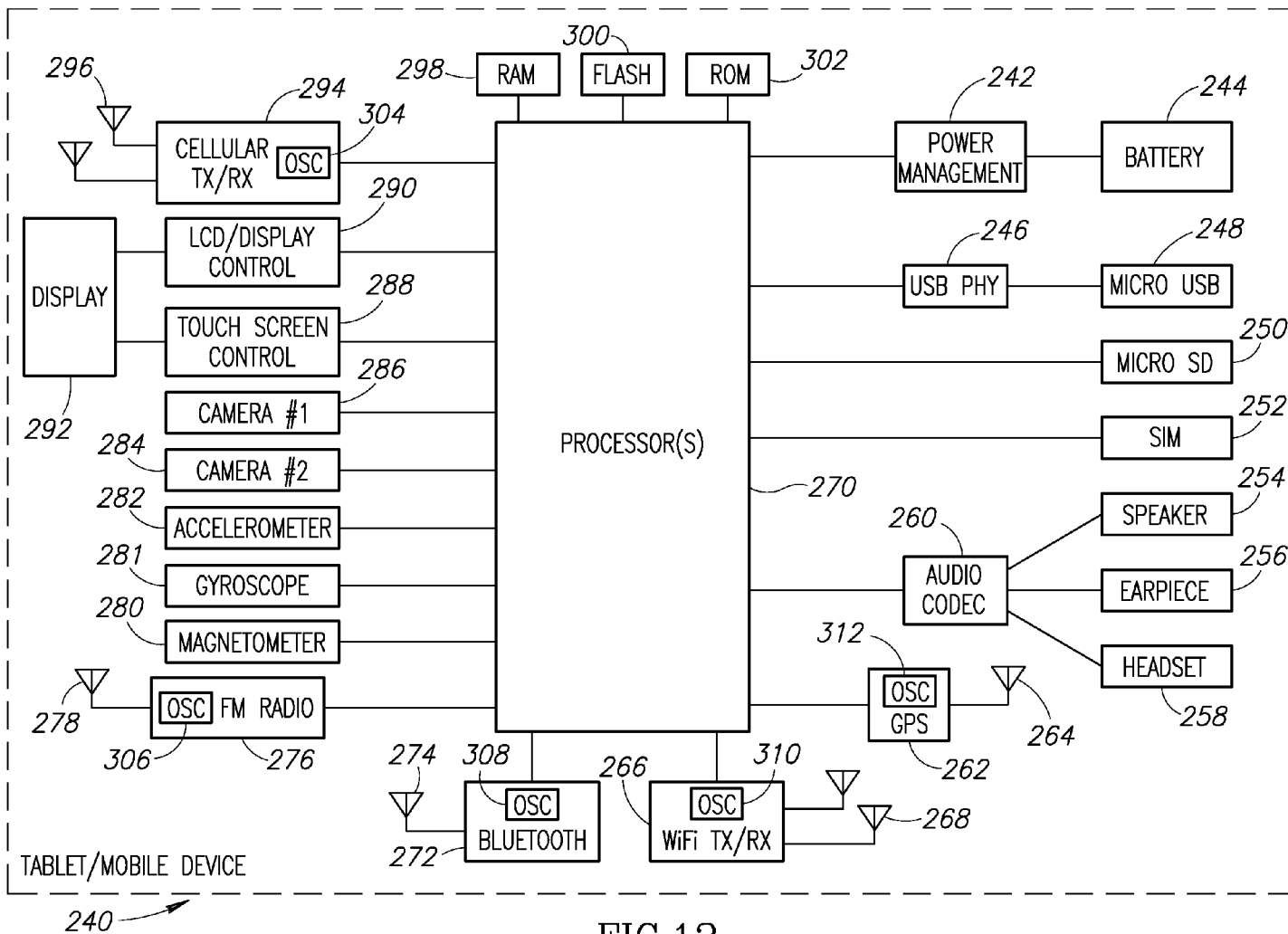

FIG.12

**SPLIT TRANSFORMER BASED DIGITALLY
CONTROLLED OSCILLATOR AND
DC-COUPLED BUFFER CIRCUIT THEREFOR**

REFERENCE TO PRIORITY APPLICATION

This application claims priority to U.S. Provisional Application Ser. No. 62/039,481, filed Aug. 20, 2014, entitled "Low-Q Transformer-Based Oscillator," incorporated herein by reference in its entirety.

FIELD OF THE INVENTION

The present invention relates generally to output buffer circuits and in particular to all NMOS or PMOS transistor DC-coupled buffer circuits for high-speed oscillators.

BACKGROUND OF THE INVENTION

Monolithic frequency synthesizers are well known and have been used as key building blocks in a wide range of applications. In communications, they generate a GHz level frequency carrier either through an inductor-capacitor (LC)-tank oscillator or a ring oscillator (RO), depending on the application's set of requirements and integrated circuit (IC) implementation tradeoffs.

Ring oscillators typically occupy a small silicon area and offer wide tuning range, thus making them flexible and inexpensive at any CMOS node, which is highly desirable in wireline systems. Their intrinsically poor phase noise (PN) and high sensitivity to supply voltage variations (i.e. frequency pushing), however, limit their use and often require either very complex calibration or high power-supply ripple rejection ratio (PSRR) low drop out regulators (LDOs) that employ large capacitors, thus effectively reducing their area advantage.

On the other hand, LC-tank oscillators inherently feature much lower phase noise and frequency pushing. Their power efficiency is superior due to a high quality (Q)-factor of their inductor. The frequency pushing is mostly related to a voltage dependence of their active devices' parasitic capacitances. Some classes of LC-tank oscillators, such as class-F or class-C, with an inductor or a transformer, exhibit small frequency pushing since their active devices require biasing networks of zero dc current, thus promoting effective filtering of dynamic variations (i.e. noise, ripple) on the supply line V_{DD} .

Drawbacks of LC-tank oscillators, however, include (1) their large size and (2) narrow tuning range. There are a few cases in prior art literature where small inductors were designed (1) by stacking metal layers in a vertical solenoid fashion or (2) by plenary shrinking the inductor. In the former case, the area obtained was extremely small, but its tuning range of only 5-10% was impractical in the face of process variations. In the latter case, the large number of turns caused the inductor to be very sensitive to its surroundings, requiring the same techniques used for large inductors to avoid Q-factor deterioration, such as complete inductor isolation, which is not permitted anymore in advanced technologies.

Although wide tuning range can be achieved with high-Q oscillators, as in dual mode, similar techniques employed to conventional LC-tank oscillators impose severe constraints on area and, consequently, coupling to nearby circuits. A switched-inductor topology has been proposed which was possible due to a combination with a pair of analog varactors as coarse/fine tuning banks, but with extremely high sensitiv-

ity (worst case on the order of 2.5 GHz/V), requiring a very stable control voltage (and thus a large capacitor) that would reduce any size advantage.

Based on the above observations of prior art attempts at compact oscillators, the desired oscillator would combine superior PN and frequency pushing of an LC-tank oscillator with low area and wide tuning range (i.e. 2:1 tuning range is required to generate an arbitrarily lower frequency through an integer division) of an RO. Furthermore, to exploit the scaling of CMOS technology, a digital manner of frequency tuning would be desired.

SUMMARY OF THE INVENTION

The present invention is an LC-tank oscillator incorporating a split transformer configuration. The LC-tank oscillator exhibits a significant reduction in area such that it is comparable in size to conventional ring oscillators (ROs) while still retaining its salient features of excellent phase noise and low sensitivity to supply variations. The oscillator incorporates an ultra-compact split transformer topology that is less susceptible to common-mode electromagnetic interference than regular high-Q LC tanks which is highly desirable in SoC environments. The oscillator, together with a novel dc-coupled buffer, can be incorporated within a wide range of circuit applications, including for example a conventional phase locked loop (PLL), all-digital phase-locked loop (AD-PLL), wireline transceiver circuits and mobile devices.

There is therefore provided in accordance with the present invention, an output buffer for use with a high frequency oscillator, comprising first and second transistors coupled in totem pole fashion, each transistor having gate, drain and source terminals, third and fourth transistors coupled in totem pole fashion, each transistor having gate, drain and source terminals, wherein the drain terminals of the second and fourth transistors coupled to a supply, wherein the gate terminals of the first and fourth transistors are directly dc coupled to a first output of the oscillator, wherein the gate terminals of the second and third transistors are directly dc coupled to a second output of the oscillator, and wherein the first, second, third and fourth transistors are all of the same transistor type.

There is also provided in accordance with the present invention, an output buffer for use with a high frequency oscillator, comprising first and second transistors coupled in totem pole fashion, each transistor having gate, drain and source terminals, third and fourth transistors coupled in totem pole fashion, each transistor having gate, drain and source terminals, wherein the drain terminals of the second and fourth transistors coupled to a supply, wherein the gate terminals of the first and fourth transistors are each ac coupled to a first port of an input signal via a coupling capacitor, wherein the gate terminals of the second and third transistors are each ac coupled to second port of an input signal, and wherein the first, second, third and fourth transistors are all of the same transistor type.

BRIEF DESCRIPTION OF THE DRAWINGS

The invention is herein described, by way of example only, with reference to the accompanying drawings, wherein:

FIG. 1 is a high level schematic diagram illustrating an example inverter ring oscillator of the present invention;

FIG. 2A is a schematic diagram illustrating an example split transformer based oscillator of the present invention;

FIG. 2B is a schematic diagram illustrating an example switched capacitor unit;

FIG. 2C is a schematic diagram illustrating example V_B filter;

FIG. 3 is a top down view illustrating the layout of the oscillator transformer and capacitor bank and the cancellation of the magnetic fields;

FIG. 4 is a perspective view illustrating layout of the oscillator transformer and capacitor bank and the cancellation of the magnetic fields;

FIG. 5 is a graph illustrating the simulated coupling factor for a typical inductor;

FIG. 6 is a diagram illustrating the capacitor bank of the oscillator in more detail;

FIG. 7A is a schematic diagram illustrating a first stage of an example DC coupled low voltage oscillator output buffer circuit of the present invention;

FIG. 7B is a graph illustrating the half circuit large signal excursion of the buffer of FIG. 7A;

FIG. 7C is a schematic diagram illustrating an example half circuit small signal simplified model of the output buffer of the present invention;

FIG. 8 is a schematic diagram illustrating a second stage of an example DC coupled low voltage oscillator output buffer circuit of the present invention;

FIG. 9 is a block diagram illustrating an example phase locked loop incorporating the oscillator of the present invention;

FIG. 10 is a block diagram illustrating an example all digital phase locked loop incorporating the oscillator of the present invention;

FIG. 11 is a block diagram illustrating an example wireline transceiver incorporating the oscillator of the present invention; and

FIG. 12 is a block diagram illustrating an example mobile device incorporating the oscillator of the present invention.

DETAILED DESCRIPTION OF THE INVENTION

The present invention provides an LC-tank oscillator incorporating a split transformer configuration. The LC-tank oscillator exhibits a significant reduction in area such that it is comparable in size to conventional ring oscillators (ROs) while still retaining its salient features of excellent phase noise and low sensitivity to supply variations. The oscillator incorporates an ultra-compact split transformer topology that is less susceptible to common-mode electromagnetic interference than regular high-Q LC tanks, which is highly desirable in SoC environments. The oscillator, together with a novel dc-coupled buffer, can be incorporated within a wide range of circuit applications, including for example a conventional phase locked loop (PLL), all-digital phase-locked loop (ADPLL), wireline transceiver circuits and mobile devices.

The oscillator of the present invention combines superior PN and frequency pushing of an LC-tank oscillator with the low area and wide tuning range of an RO. Furthermore, to exploit the scaling of CMOS technology, digital frequency tuning is provided. An example transformer-based digitally controlled oscillator (DCO) constructed by the inventors achieved a 20 dB figure-of-merit (FoM) improvement over prior art ROs. FoM is a quality measure of oscillators taking into account the free-running phase noise (PN), power consumption P_{DC} and operating frequency (f_0) and is given by the following.

$$FoM = |PN| + 20 \cdot \log_{10} \left(\frac{f_0}{\Delta f} \right) - 10 \cdot \log_{10} \left(\frac{P_{DC}}{1 \text{ mW}} \right) \quad (1)$$

FoM_T given by the equation below further includes the tuning range (TR).

$$FoM_T = FoM + 20 \cdot \log_{10} \left(\frac{TR[\%]}{10} \right) \quad (2)$$

An example application of the transformer-based DCO of the present invention in an ADPLL circuit is provided infra. The transformer-based DCO, along with a novel dc-coupled output buffer, provides 23 dB better FoM_T than a conventional RO based circuit with the same area (120×120 μm²), while offering wide tuning range, robustness to supply variations and far-field cancellation.

A high level schematic diagram illustrating an example ring oscillator (RO) of the present invention is shown in FIG. 1. The single-ended or non-differential RO circuit, generally referenced 10, comprises an odd plurality of inverters 12. Each inverter has associated with it a series of switches (of varying resistance or strength) 14 to V_{DD} , switches (of varying resistance or strength) 16 to ground and one or more switched 19 capacitors 18. The switches 14, 16 and switched capacitors 18 all contribute to the frequency tuning of the RO.

In one embodiment, the RO is implemented as 3-stage current-starved topology shown in FIG. 1. The frequency tuning is performed exclusively by digital controls with very coarse steps (i.e. tuning band) provided by switching the switches 14 and 16 (or alternatively transistors acting as current sources) and finer frequency steps by single-ended switched capacitors. The capacitors are divided between 4-bit binary-weighted coarse, 30-bit unit-weighted mid-coarse and 15-bit unit-weighted fine banks. Also, a 3-bit unit-weighted bank for second order MASH $\Sigma\Delta$ dithering is implemented to enhance frequency resolution.

To ensure the circuit symmetry and balance, the coarse and mid-coarse banks are switched at the same time at all three DCO phases. For the fine bank and the $\Sigma\Delta$ dithering capacitors, the control is applied to only one of the DCO phases at a time in a thermometer manner so a finer resolution is achieved with monotonic frequency steps. All capacitors are based on a unit cell with an nMOS switch and a metal-oxide-metal (MOM) capacitor that are combined in groups according to the desired bank capacitance. Moreover, the RO uses a single-ended topology since it provides better FoM when compared to its counterpart (pseudo-) differential topology.

As described supra, ring oscillators typically occupy a small silicon area and offer wide tuning range, thus making them flexible and inexpensive at any CMOS node, which is highly desirable in wireline systems. Their intrinsically poor phase noise (PN) and high sensitivity to supply voltage variations (i.e. frequency pushing), however, limit their use and often require either very complex calibration or high power-supply ripple rejection ratio (PSRR) low drop out regulators (LDOs) that employ large capacitors, thus effectively reducing their area advantage.

A schematic diagram illustrating an example split transformer based digitally controlled oscillator (DCO) of the present invention is shown in FIG. 2A. A schematic diagram illustrating an example switched capacitor unit is shown in FIG. 2B. A schematic diagram illustrating example V_B filter is shown in FIG. 2C. The DCO circuit, generally referenced 20,

comprises an active transistor pair **40**, **42**, having an input (i.e. transistor gate terminals) and output (i.e. drain terminals), cross coupled to a passive LC-tank circuit including split transformers **21**, **22** and a plurality of digitally controlled switched capacitor banks **32**, **34**, **36**, **38** providing a frequency tuning function for the DCO. Transformer **21** comprises primary winding **24** (i.e. input) connected between the drain of transistor **42** and V_{DD} and secondary winding **26** (i.e. output) coupled between the gate of transistor **40** and V_B . Transformer **22** comprises primary winding **28** (i.e. input) connected between the drain of transistor **40** (i.e. output) and V_{DD} and secondary winding **30** coupled between the gate of transistor **42** and V_B .

The low Q-factor transformer based DCO comprises two small form-factor transformers split into two single ended transformers. In one embodiment, the Q factor of the transformer is about 8-10. The capacitor banks are configured depending on the desired frequency tuning range. Capacitor banks are provided for frequency acquisition, tracking and compensating for PVT variations. The acquisition capacitor banks include unit weighted digital control and, in one embodiment, are only applied to the transformer secondary windings. The tracking capacitor banks include unit weighted digital control and, in one embodiment, are qualitatively identical to the acquisition bank and are only applied to the transformer primary windings.

The switched capacitor unit, generally referenced **56**, comprises auxiliary transistor switches **58**, **60**, main transistor switch **66** and capacitors **62**, **64**. The RC filter circuit, generally referenced **50**, comprises resistor **52** and capacitor **54** that form a low pass filter having a cutoff frequency f_{-3dB} of approximately 400 kHz.

Typically, scaling down an inductive element is very challenging. It requires multiple optimizations to deliver the salient features of an RO, such as wide tuning range and small area, while keeping high power efficiency (i.e. better PN with less power). The goal is to squeeze a sufficient inductance in a small area without drastically degrading the Q-factor. In addition, the parasitic capacitance is preferably kept low which infers high self-resonance frequency (SRF) so that the desired tuning range can be achieved and at the same time meet stringent metal density requirements.

The large size of high-Q inductors inevitably makes them very sensitive to their surroundings since they act like antennas. By either picking up noise or inducing currents in nearby circuits these inductors could potentially lead to various operational issues such as frequency pulling of two or more close-by oscillators or noise induction in analog circuits which would require special countermeasures. Maintaining the inductor isolation and space between the circuits is expensive due to extra silicon and is not always possible due to stringent metal density rules.

A top down view illustrating the layout of the oscillator transformer and capacitor bank and the cancellation of the magnetic fields is shown in FIG. 3. In one embodiment, the LC-tank circuit, generally referenced **70**, comprises a first half **71** of the split transformer having a turns ratio of 1:2 and associated capacitor bank **88** and a second half **81** of the split transformer and associated capacitor bank **90**. The first half **71** of the transformer comprises primary winding **74** and secondary winding **72**. Dot **76** indicates the magnetic field \vec{B} projecting out of the figure while crosses **78** show the field going into the figure. The second half **81** of the transformer comprises primary winding **82** and secondary winding **80**.

Dots **84** indicates the magnetic field \vec{B} projecting out of the figure while cross **86** show the field going into the figure. A

perspective view illustrating layout of the oscillator transformer and capacitor bank and the cancellation of the magnetic fields is shown in FIG. 4. In this example embodiment, the chip area of the LC-tank circuit including split transformer windings **102**, **104** and corresponding capacitor banks **106**, **108** takes up $120 \times 120 \mu\text{m}^2$.

One technique to deal with the strong magnetic fields from large inductors is to use octagonal shaped inductors, which provides field cancellation. For compact oscillators, however, more elaborate structures are required which restricts the beneficial use of transformers. In the split topology of the present invention, shown in FIGS. 3 and 4, the magnetic fields \vec{B} generated by the transformer windings are in opposite direction to each other, according to the injected current (in this example embodiment they are differential), either in the inner or outer coils, with a slightly different magnitude. Moreover, due to their small size, the destructive effect of the magnetic field inside the coils is negligible, keeping the Q-factor and inductance unchanged. For their surroundings, however, the reminiscent \vec{B} fields have opposite phases and are largely canceled out.

In order to quantify the magnetic interaction of the inductors with their surroundings, we can analyze the coupling factor k_m between the inductors and another (imaginary test) coil, which is in this case single-turn. This approach quantifies the relative disturbance in relation to a distance from the center. The single-turn coil is used to average out the electromagnetic coupling at a certain distance d . Note that here the electric field also plays a role, due to capacitive interaction. The structure of the split transformer achieves relatively small size thereby minimizing the overall magnetic field. The placement of the two individual transformers causes the magnetic far fields to cancel out. This lowers the electromagnetic interference (EMI) and improves the electromagnetic compatibility (EMC) with highly dense SoCs.

FIG. 5 shows the normalized k_m between inner and outer inductors to the single-turn test coil, in the direction θ of 45 degrees. When properly driven, i.e. differentially, it provides magnetic field cancellation, as expected. For comparison, the same structure was stimulated in a single-ended way, meaning that the magnetic fields of both coils have the same phase, exactly how we would expect from a typical inductor. The efficiency of the field cancellation can be shown first by the coupling magnitude, which is 75% smaller at the edge of the DCO structure and then rapidly decaying. The coupling factor between a typical inductor to another coil drops in proportion to $1/d^2$ as shown in line **110** where for the DCO of the present invention it drops in proportion to $1/d^3$ as shown in line **112**, in accordance with the well-known theory of dipoles.

Moreover, the overall magnetic field is proportional to the size of the coil, so minimizing it helps to reduce sensitivity. Thus, by qualitatively analyzing the magnetic fields and the comparison shown in FIG. 5, we expect the circuit to be very robust to common-mode magnetic fields and thus suitable to System on Chip (SoC) environments.

Finally, the inner and outer coils can be combined into a single transformer. The inner coils serving as primary and the outer coils as secondary. This combination allows us to obtain a passive gain (due to the 1:2 turns ratio, in this example embodiment) in the LC tank that is important for operation of the oscillator.

For optimum performance of the oscillator, the split transformer of the present invention is preferably driven differentially. Various aspects of the active and LC-tank circuitry that form the DCO will now be described in more detail.

The DCO of the present invention employs a transformer-based LC cross-coupled topology, with the ability to low-pass filter the gate-source bias voltage V_{GS} of the active devices. This achieves a very low frequency pushing sensitivity by minimizing gate-source capacitance C_{GS} modulation due to V_{GS} . The transformer-based digitally controlled oscillator (DCO) is shown in FIG. 2A. In one embodiment, the transformer comprises two independent multi-turn single-ended transformers **21**, **22**, using top-layer metal conductors (with a thickness of 0.85 μm), in a digital 40 nm CMOS technology without ultra-thick metals, while satisfying all restricted metal density design rule check (DRC) requirements. The two independent transformers are placed symmetrically to the center of the DCO, in order to obtain magnetic field cancellation. The turns ratio ($n=1:2$) provides passive voltage gain between the drain and gate of the transistor pair, thus reducing potential start-up problems.

In one embodiment, the design of the transformer includes pattern-ground shield in poly and 6 thin metals, and was simulated using the Method-of-Momentum. Each coil has a winding width of 2.9 μm and spacing of 1.15 μm , where the outer and inner diameters are 38.9 μm and 16.9 μm , respectively. The transformer has a coupling coefficient of 0.7, between the 350 pH primary and 1 nH secondary, peak quality factor of 8 around 13 GHz and self-resonance frequency (SRF) at 50 GHz.

The capacitor banks are divided between the primary and secondary of the transformer. The coarse banks (6-bit binary-weighted) **34**, **36** are switched simultaneously enhancing the overall Q-factor of the transformer over individual inductors. Mid-coarse bank **38** and fine bank **32** are both 14-bit unit-weighted, but the effective capacitive weight of the former is n^2 (4 in this example embodiment) larger than the latter since the mid-coarse is connected only at the secondary and the fine bank is connected only at the primary. This is possible because in a transformer, having the primary as the reference side, the impedance of the secondary scales with $1/n^2$. Note that the slight asymmetry caused by that does not degrade the Q-factor of the entire tank circuit. Moreover, it can provide the required frequency range overlap as well as fine resolution.

In another embodiment, in order to improve the effective frequency resolution, second order multi-stage noise shaping (MASH) sigma-delta ($\Sigma\Delta$) dithering is applied to one or three unit-weighted bits of the fine bank. It uses a divided version of the output frequency ($1/32$ or $1/16$) to dither capacitance of these one or three bits, effectively obtaining fractions of the minimum capacitance and consecutively finer frequency resolution.

The configuration of the switched capacitor units were described supra in connection with FIG. 2B, while the layout details are shown in FIG. 6. The layout, generally referenced **120**, comprises a differential capacitor **122**, **124** with a main switch **127** assisted by two auxiliary switches **128**. The main switch **127** is responsible for turning the capacitors on/off. Without a dc level at its source and drain, however, it would not operate at its optimum. Thus, to help turn it on, two small transistors provide a path to ground. During the off-state, the leakage current to ground through the auxiliary switches provides a high impedance dc path to ground at the source and drain, preventing any direct bias condition for the corresponding pn junctions to the substrate. Note that the design of the capacitor bank effects the operation of the DCO, especially the connection between the switch **127** and the capacitors, since excessive parasitic capacitance in these lines, due to cross-coupling, affects the minimum C_{OFF} , thus reducing the

tuning range. The capacitor bank C_{ON}/C_{OFF} ratio is approximately three with a Q-factor greater than 12.

Besides the DCO optimization for the required PN and power consumption performance, another important circuit block is the first DCO output buffer. Non-linearity of the driven load (including the buffer non-linearity itself) and supply voltage disturbance could degrade the PN and, consequently, reduce the oscillator power efficiency. In addition, the continuing technology node shrink requires voltage supply reduction, while the transistor threshold voltage (V_{th}) is kept roughly the same, requiring new buffer topologies to overcome these issues.

The oscillator output has its resonating amplitude dependent on various PVT parameters and consumed current. The voltage waveform is centered around the supply level in this case, but it could center around ground or at any level in-between for other oscillator topologies. In one embodiment, the high frequency buffer is connected to the DCO through dc blockers (i.e. decoupling capacitors) allowing the buffer bias voltage to be set internally, reducing statistical process variation (especially pMOS and nMOS mismatches). These dc blockers, however, add extra load and area to the oscillator tank and depending on the frequency could be prohibitively large. Their internal dc biasing can also generate noise that can reversely feed into the oscillator. In another embodiment, the buffer is dc-coupled to the oscillator. A source-follower configuration uses dc coupling and exhibits wideband frequency response but often offers voltage gain well below unity.

In order to increase its power efficiency, the present invention provides a buffer having a combined source follower and common-source topology. A schematic diagram illustrating a first stage of an example DC coupled low voltage oscillator output buffer circuit of the present invention is shown in FIG. 7A. A graph illustrating the half circuit large signal excursion of the buffer of FIG. 7A is shown in FIG. 7B. A schematic diagram illustrating an example half circuit small signal simplified model of the output buffer of the present invention is shown in FIG. 7C.

In one embodiment, the buffer, generally referenced **130**, is dc coupled to the DCO via inputs labeled OUT_p and OUT_m , shares the same V_{DD} supply voltage and uses only nMOS devices in order to reduce capacitive loading, noise and process mismatches, respectively. In an alternative embodiment, the buffer may use only pMOS devices which could correspond to a case of a pMOS based oscillator with an average value of the single ended oscillator waveform voltage around zero. The buffer comprises four transistors M_1 , M_2 , M_3 and M_4 . Transistor pairs M_1 and M_2 , and M_3 and M_4 are arranged in totem pole fashion. In this configuration, the nMOS transistors belonging to M_1/M_2 pair, as well as M_3/M_4 pair, are stacked between V_{DD} and ground. The gates of M_1 and M_4 form one of the inputs connected to OUT_p from the DCO. The gates of M_2 and M_3 form the other input that is connected to OUT_m from the DCO. The drains of M_2 and M_4 are connected to V_{DD} and the sources of M_1 and M_3 form are connected to ground. The source/drain connection of transistors M_2 and M_1 , respectively, form one of the outputs OUT_m buf. The source/drain connection of transistors M_4 and M_3 , respectively, form one of the outputs OUT_p buf.

From FIGS. 7A and 7B it can be seen that V_{GS2} is kept constant and equal to $(V_{DD}-V_{DS1})$ which is chosen to be below the threshold voltage (V_{th}). In this manner, M_2 and M_4 operate in weak inversion and M_1 and M_3 operate in strong inversion since both share the same current and M_2 and M_4 are 4x larger than M_1 and M_3 . For a short period of time, however, around 90 degrees and 270 degrees of the cycle, either one of

the transistors enters the triode region (see traces **134**, **136**, **138**) but that does not affect the overall performance since the other transistor is providing ac gain to the corresponding output. Also, due to a relatively small voltage swing (250 mV_p in this embodiment), this linear region is reached only for a very short time. Thus, for the analysis, we can still treat the circuit using a small-signal model.

FIG. 7C illustrates the small-signal simplified model of the left half of the circuit of FIG. 7A. The current reuse is represented by the inclusion of gm₁ in the gain. The circuit architecture provides compensation for the gate-source capacitance of M₂ (C_{gs2}), contributing to an overall voltage gain enhancement of 20% in this example embodiment, when compared to a simple source follower. The voltage gain enhancement, however, depends on the driven load where the differential overall gain is given by:

$$A_v = \frac{gm_1 + gm_2 + s(C_{gs2} - C_{gd1})}{gm_2 + 1/Z_L + s(C_{gs2} - C_{gd1})} \quad (3)$$

where Z_L is the parallel association of the output impedance of the transistors (both output resistance and capacitance) with the load. The buffer output impedance is given by the following:

$$Z_{out} = \left(\frac{1}{Z_L} + \frac{gm_1 C_{gd1}}{C_{gd1} + C_{gs1}} + \frac{gm_2 C_{gs2}}{C_{gd2} + C_{gs2}} \right)^{-1} \quad (4)$$

In one embodiment, the transformer based DCO is packed in a square of 120×120 μm², including the transformer, capacitor banks, active core, output buffer and decoupling capacitors. Note that current process technology has very stringent manufacturing rules that must be followed. Previously, metal density over larger inductors could be waived with the designer taking responsibility. Today, however, one side of the die might affect the other and semiconductor foundries are reluctant to permit it. The problem is that high-Q inductors depend on the metal emptiness around them to perform well and this is a main challenge for RF circuit designers with future technologies. Thus, one advantage of keeping the inductor (or transformer in the DCO of the present invention) small is that any metal density requirements are easier to fulfill. Another advantage is that the magnetic field is kept mostly around the windings of the transformer, which contributes to lower interference on its surroundings. Further, the split transformer architecture of the invention reduces even more the far-field through field cancellation thus isolating the DCO from the environment.

A schematic diagram illustrating a second stage of an example DC coupled low voltage oscillator output buffer circuit of the present invention is shown in FIG. 8. The buffer circuit, generally referenced **150**, comprises differential input terminal IN_p coupled to transistors **154**, **155** via capacitors **160**, **162**, respectively, and input terminal IN_m coupled to transistors **152**, **156** via capacitors **158**, **164**, respectively,

Several applications of the DCO of the present invention as a frequency generator will now be described.

A block diagram illustrating an example phase locked loop (PLL) incorporating the oscillator of the present invention is shown in FIG. 9. The PLL, generally referenced **160**, comprises a reference oscillator **162**, +N divider **164**, phase/frequency detector **166**, charge pump **168**, low pass filter **170**,

voltage controlled oscillator (VCO) **172** incorporating the oscillator of the present invention, programmable +M divider **174** and ΣΔ modulator **176**.

A block diagram illustrating an example all digital phase locked loop (ADPLL) incorporating the oscillator of the present invention is shown in FIG. 10. The frequency command word (FCW) **182** is split into its integer FCW_I and fractional parts FCW_F, with separate reference accumulators **184**, **202** that generate the integer and fractional part of the reference phase, PHR_I and PHR_F, respectively. In order to properly accumulate the FCW as a whole, a carry is transferred to the integer accumulator whenever an overflow of the fractional part occurs. A synchronous 8-bit counter serves as the variable accumulator and produces the variable phase PHV that is subtracted from PHR_I via subtractor **186** to provide the integer part of the phase error PHE_I. PHR_F is used to calculate the TDC delay code based on the estimated delay characteristic of the TDC, which in turn is applied to the look-ahead TDC **198** through a gain. A TDC gain estimation block **200**, based on an iterative adaptation algorithm, is implemented on chip to dynamically track delay estimation errors due to PVT variations. The digitized output of the TDC represents the fractional part of the phase error, PHE_F that is combined with PHE_I via summer **188** to yield the total fixed-point representation of the phase error PHE.

The phase error PHE is then filtered via loop filter **190**, in order to properly set the dynamics of the loop. A reconfigurable proportional integral controller within the loop filter block **190** is followed by a DCO decoder also within the loop filter block **190** to generate the oscillator tuning word (OTW). The DCO **192** comprises the DCO circuit described supra in connection with FIGS. 2A, 2B, 2C and includes switched capacitor banks that are dithered using a 2nd-order MASHΣΔ modulator in order to achieve a lower equivalent frequency resolution and push the quantization noise at higher offset frequencies where they are more easily filtered out and do not contribute significantly to the total jitter. The operation frequency of the ΣΔ modulators can be dynamically selected between different divider versions of the oscillator output in order to meet the required performance as a trade-off between power consumption and jitter.

In one embodiment, for the feasibility of the variable accumulator implementation, the feedback path was chosen to operate at a maximum 2.5 GHz, which means that a divide-by-eight version of the transformer-based DCO output is fed back to the variable accumulator and the look-ahead TDC. Division by eight is achieved using a current mode logic (CML) +4 divider cascaded with a CMOS digital divider. These dividers are represented in FIG. 10 by the +N block **194**. Since the loop feedback operates on a divided version of the output, the effective frequency command word is adjusted accordingly. Therefore, one eighth of the multiplication ratio is accumulated at the ADPLL.

As mentioned supra, the retimer clock gating circuit **196** generates the clock signals for the ADPLL. The CKR clock is used as a global digital clock of the ADPLL loop (at the reference clock rate) to resample the output of the variable accumulator and to generate a gated version of the variable feedback clock CKV_{gtd}.

A block diagram illustrating an example wireline transceiver incorporating the oscillator of the present invention is shown in FIG. 11. The transceiver, generally referenced **210**, comprises a DSP/processor (including a baseband processor in one embodiment) **212**, transmitter **214**, receiver **224**, PLL based frequency generator **222** and the channel (e.g., wired or optical) **234**. The transmitter **214** comprises a serializer **216**, TX equalizer **218** and driver **220**. The receiver **224** comprises

a low noise amplifier (LNA) **226**, RX equalizer **230**, clock data recovery (CDR) **228** and deserializer **232**.

In this example embodiment, the frequency generator **222** comprises the ADPLL incorporating the transformer-based DCO as described supra in connection with FIG. **10**. The transformer based ADPLL makes use of the intrinsically better spectrum purity offered by LC DCOs within a tiny area. It efficiently trades silicon area with jitter while offering a wide tuning range which is highly desirable in wireline systems.

Moreover, the transformer based ADPLL provides (1) a >45% tuning range, (2) very small frequency pushing and (3) using the split transformer topology described supra, more robustness to common-mode magnetic field interference which is highly desirable in very spectrally polluted environments commonly found in SoCs.

Mobile Device Incorporating the Split Transformer DCO

A block diagram illustrating an example mobile device incorporating the digitally controlled oscillator of the present invention is shown in FIG. **12**. The mobile device is preferably a two-way communication device having voice and/or data communication capabilities. In addition, the device optionally has the capability to communicate with other computer systems via the Internet. Note that the mobile device may comprise any suitable wired or wireless device such as multimedia player, mobile communication device, digital still or video camera, cellular phone, smartphone, iPhone, PDA, PNA, Bluetooth device, tablet computing device such as the iPad or other iOS device, Android device, Surface, Nexus, Google Glass, etc. For illustration purposes only, the device is shown as a mobile device, such as a cellular based telephone, smartphone or superphone. Note that this example is not intended to limit the scope of the DCO as the invention can be implemented in a wide variety of communication devices. It is further appreciated the mobile device shown is intentionally simplified to illustrate only certain components, as the mobile device may comprise other components and subsystems beyond those shown.

The mobile device, generally referenced **240**, comprises one or more processors **270** which may comprise a baseband processor, CPU, microprocessor, DSP, etc., optionally having both analog and digital portions. The mobile device may comprise a plurality of cellular radios **294** and associated antennas **296**. Radios for the basic cellular link and any number of other wireless standards and Radio Access Technologies (RATs) may be included. Examples include, but are not limited to, Third Generation (3G) Long Term Evolution (LTE), Code Division Multiple Access (CDMA), Personal Communication Services (PCS), Global System for Mobile Communication (GSM)/GPRS/EDGE 3G; WCDMA; WiMAX for providing WiMAX wireless connectivity when within the range of a WiMAX wireless network; Bluetooth for providing Bluetooth wireless connectivity when within the range of a Bluetooth wireless network; WLAN for providing wireless connectivity when in a hot spot or within the range of an ad hoc, infrastructure or mesh based wireless LAN (WLAN) network; near field communications; UWB; GPS receiver for receiving GPS radio signals transmitted from one or more orbiting GPS satellites, FM transceiver provides the user the ability to listen to FM broadcasts as well as the ability to transmit audio over an unused FM station at low power, such as for playback over a car or home stereo system having an FM receiver, digital broadcast television, etc.

The mobile device may also comprise internal volatile storage **298** (e.g., RAM) and persistent storage **302** (e.g., ROM) and flash memory **300**. Persistent storage **302** also stores applications executable by processor(s) **270** including the related data files used by those applications to allow device **240** to perform its intended functions. Several optional user-interface devices include trackball/thumbwheel, which may comprise a depressible thumbwheel/trackball that is used for navigation, selection of menu choices and confirmation of action, keypad/keyboard such as arranged in QWERTY fashion for entering alphanumeric data and a numeric keypad for entering dialing digits and for other controls and inputs (the keyboard may also contain symbol, function and command keys such as a phone send/end key, a menu key and an escape key), headset **258**, earpiece **256** and/or speaker **254**, microphone(s) and associated audio codec **260** or other multimedia codecs, vibrator for alerting a user, one or more cameras and related circuitry **286**, **284**, display(s) **292** and associated display controller **290** and touchscreen control **288**. Serial ports include a micro USB port **248** and related USB PHY **246** and micro SD port **250**. Other interface connections may include SPI, SDIO, PCI, USB, etc. for providing a serial link to a user's PC or other device. SIM/RUIM card **252** provides the interface to a user's SIM or RUIM card for storing user data such as address book entries, user identification, etc.

Portable power is provided by the battery **244** coupled to power management circuitry **242**. External power is provided via USB power or an AC/DC adapter connected to the power management circuitry that is operative to manage the charging and discharging of the battery. In addition to a battery and AC/DC external power source, additional optional power sources each with its own power limitations, include: a speaker phone, DC/DC power source, and any bus powered power source (e.g., USB device in bus powered mode).

Operating system software executed by the processor **270** is preferably stored in persistent storage (i.e. ROM **302**), or flash memory **300**, but may be stored in other types of memory devices. In addition, system software, specific device applications, or parts thereof, may be temporarily loaded into volatile storage **298**, such as random access memory (RAM). Communications signals received by the mobile device may also be stored in the RAM.

The processor **270**, in addition to its operating system functions, enables execution of software applications on the device **240**. A predetermined set of applications that control basic device operations, such as data and voice communications, may be installed during manufacture. Additional applications (or apps) may be downloaded from the Internet and installed in memory for execution on the processor. Alternatively, software may be downloaded via any other suitable protocol, such as SDIO, USB, network server, etc.

Other components of the mobile device include an accelerometer **282** for detecting motion and orientation of the device, gyroscope **281** for measuring or maintaining orientation, magnetometer **280** for detecting the earth's magnetic field, FM radio **276** and antenna **278**, Bluetooth radio **272** and antenna **274**, Wi-Fi radio **266** including antenna **268** and GPS **262** and antenna **264**.

In accordance with the invention, the mobile device **240** comprises one or more DCO circuits of the present invention. Numerous embodiments of the mobile device **240** may comprise a DCO circuit **304** as described supra incorporated in the one or more cellular radios **294**; a DCO circuit **306** as described supra incorporated in the FM radio **276**; a DCO circuit **308** as described supra incorporated in the Bluetooth radio **272**; a DCO circuit **310** as described supra incorporated

in the Wi-Fi radio **266**; and a DCO circuit **312** as described supra incorporated in the GPS radio **262**.

The DCO of the present invention has been fabricated in a digital low-power 40 nm CMOS technology having an active area of 0.0625 mm². The FoM and FoM_r of the transformer-based DCO are 175 dB and 188 dB, respectively. The transformer-based DCO operates at 1 V supply. For the transformer-based ADPLL described supra, the worst fractional spur measured was -47 dBc and the reference spur -56 dBc. The maximum integrated jitter (from 10 kHz to 100 MHz) measured 0.78 ps_{rms}. The fractional spurs were located outside the ADPLL loop bandwidth since the target application (e.g., wireline systems) does not require such small fractional-N channels. The DCO of the present invention thus offers a very efficient way to trade off area with jitter, while keeping power efficiency best-in-class. The DCO achieves this by incorporating the advantages of both worlds, i.e. from the superior quality factors of LC tanks to the small size and wide tuning range of a RO which has utility in numerous applications, such as mobile devices and wireline systems.

The terminology used herein is for the purpose of describing particular embodiments only and is not intended to be limiting of the invention. As used herein, the singular forms “a”, “an” and “the” are intended to include the plural forms as well, unless the context clearly indicates otherwise. It will be further understood that the terms “comprises” and/or “comprising,” when used in this specification, specify the presence of stated features, integers, steps, operations, elements, and/or components, but do not preclude the presence or addition of one or more other features, integers, steps, operations, elements, components, and/or groups thereof.

The corresponding structures, materials, acts, and equivalents of all means or step plus function elements in the claims below are intended to include any structure, material, or act for performing the function in combination with other claimed elements as specifically claimed. The description of the present invention has been presented for purposes of illustration and description, but is not intended to be exhaustive or limited to the invention in the form disclosed. As numerous modifications and changes will readily occur to those skilled in the art, it is intended that the invention not be limited to the limited number of embodiments described herein. Accordingly, it will be appreciated that all suitable variations, modifications and equivalents may be resorted to, falling within the spirit and scope of the present invention. The embodiments were chosen and described in order to best explain the principles of the invention and the practical application, and to enable others of ordinary skill in the art to understand the invention for various embodiments with various modifications as are suited to the particular use contemplated.

What is claimed is:

1. An output buffer for use with a high frequency oscillator, comprising:

first and second transistors coupled in totem pole fashion, each transistor having gate, drain and source terminals; third and fourth transistors coupled in totem pole fashion, each transistor having gate, drain and source terminals; wherein the drain terminals of said second and fourth transistors are coupled to a supply;

wherein the gate terminals of said first and fourth transistors are directly dc coupled to a first time-varying output signal of said oscillator;

wherein the gate terminals of said second and third transistors are directly dc coupled to a second time-varying output signal of said oscillator; and

wherein said first, second, third and fourth transistors are all of the same transistor type.

2. The output buffer according to claim **1**, wherein said first, second, third and fourth transistors comprise nMOS transistors.

3. The output buffer according to claim **1**, wherein said first, second, third and fourth transistors comprise pMOS transistors.

4. The output buffer according to claim **1**, wherein the gate to source voltage of said second and fourth transistors is maintained substantially constant.

5. The output buffer according to claim **1**, wherein the gate to source voltage of said second and fourth transistors is less than a threshold voltage V_{th} .

6. The output buffer according to claim **1**, wherein the size of said second and fourth transistors is substantially larger than that of said first and third transistors, respectively.

7. The output buffer according to claim **1**, wherein the size of said second and fourth transistors is approximately four times that of said first and third transistors, respectively.

8. The output buffer according to claim **1**, wherein the supply of said buffer is connected to a supply of said oscillator.

9. An output buffer for use with a high frequency oscillator, comprising:

first and second transistors coupled in totem pole fashion, each transistor having gate, drain and source terminals; third and fourth transistors coupled in totem pole fashion, each transistor having gate, drain and source terminals; wherein the drain terminals of said second and fourth transistors are coupled to a supply; wherein the gate terminals of said first and fourth transistors are each ac coupled to a first port of a time-varying input signal via a coupling capacitor;

wherein the gate terminals of said second and third transistors are each ac coupled to second port of a time varying input signal; and

wherein said first, second, third and fourth transistors are all of the same transistor type.

10. The output buffer according to claim **9**, wherein said first, second, third and fourth transistors comprise nMOS transistors.

11. The output buffer according to claim **9**, wherein said first, second, third and fourth transistors comprise pMOS transistors.

12. The output buffer according to claim **9**, wherein the gate to source voltage of said second and fourth transistors is maintained substantially constant.

13. The output buffer according to claim **9**, wherein the gate to source voltage of said second and fourth transistors is less than a threshold voltage V_{th} .

14. The output buffer according to claim **9**, wherein the size of said second and fourth transistors is approximately four times that of said first and third transistors, respectively.

15. The output buffer according to claim **9**, wherein the size of said second and fourth transistors is substantially larger than that of said first and third transistors, respectively.

16. The output buffer according to claim **9**, wherein the supply of said buffer is connected to a supply of said oscillator.

17. An output buffer for use with a high frequency oscillator, comprising:

first and second transistors coupled in totem pole fashion, each transistor having gate, drain and source terminals; third and fourth transistors coupled in totem pole fashion, each transistor having gate, drain and source terminals;

a differential output of said output buffer taken from a first node connecting said first and second transistors and a second node connecting said third and fourth transistors; wherein the drain terminals of said second and fourth transistors are coupled to a supply; 5
wherein the gate terminals of said first and fourth transistors are directly dc coupled to a first time varying output signal of said oscillator and the gate terminals of said second and third transistors are directly dc coupled to a second time varying output signal of said oscillator; 10
wherein said second and fourth transistors are configured to operate in relatively weak inversion mode and said first and third transistors are configured to operate in relatively strong inversion mode; and
wherein said first, second, third and fourth transistors are 15
all of the same transistor type.

18. The output buffer according to claim 17, wherein the gate to source voltage of said second and fourth transistors is less than a threshold voltage V_{th} .

19. The output buffer according to claim 17, wherein the size of said second and fourth transistors is approximately four times that of said first and third transistors, respectively. 20

20. The output buffer according to claim 17, wherein the size of said second and fourth transistors is substantially larger than that of said first and third transistors, respectively. 25

* * * * *